

# Part L 2021

## Where to start



A guide for housebuilders and their advisors  
Masonry construction

24.04.2023

April 2023 update

## Acknowledgements

This guide was designed and illustrated by Studio Partington on behalf of the Future Homes Hub.

We would like to thank everyone who helped to put this report together. In addition to the Steering Group members listed below, we are also very grateful to all those who contributed as individuals or were members of our expert sub-groups: Customer Group, Direct Electric Group, Electrical Infrastructure Group, Fabric Group, Heat Pump Group, Hot Water Group.

Steering group members:

<b>Adrian Leithead</b>	Elmhurst Energy	<b>Jamie Bursnell</b>	Bellway Homes
<b>Alex Brooks</b>	AES Sustainability Consultants	<b>Julie Godefroy</b>	CIBSE
<b>Alex Taylor</b>	NHBC	<b>Oliver Novakovic</b>	Barratt Homes
<b>Andrew Orriss</b>	Structural Timber Association	<b>Dr Rachel Mitchell</b>	Passivhaus Trust
<b>Chris Carr</b>	Federation of Master Builders	<b>Richard Partington</b>	Studio Partington
<b>Chris Ricketts</b>	Elmhurst Energy	<b>Rory Bergin</b>	HTA Design LLP
<b>Dr Clifford Fudge</b>	H+H UK	<b>Trudie McCormick</b>	Keepmoat Homes
<b>Danielle Michalska</b>	Barratt Homes	<b>Victoria Tink</b>	DLUHC
<b>Ian Faulkner</b>	Countryside Partnerships	<b>Chris Gaze</b>	Future Homes Hub
<b>Jack Brayshaw</b>	Vistry Group	<b>David Adams</b>	Future Homes Hub
		<b>Tessa Hurstwyn</b>	Future Homes Hub

Special thanks to:

**Fabienne Blunden** Studio Partington

**Richard Partington** Studio Partington

Front cover image: supplied by H+H Celcon.



Supported by:



First published 15<sup>th</sup> June 2022 by Future Homes Hub

This update published April 2023 by Future Homes Hub

[www.futurehomes.org.uk](http://www.futurehomes.org.uk)

Future Homes Hub | Part L 2021 Where to start : Masonry Construction

## Foreword

We are delighted to be publishing this, our first analysis of how to deliver homes to the new Approved Document Part L (2021). Of course, it is not the only new regulation coming into force this year and so we have also shown how it links with the new Part F (Ventilation), Part O (Overheating) and Part S (Electric Vehicle Charging). More detailed advice can be found in some of our other publications.

These regulations represent a significant step forwards towards the Government's zero carbon objectives, but of course Part L is only interim; the Future Homes Standard is due to be implemented less than 3 years from now. The guide tackles this by looking at a range of built forms and then looking at variety of fabric (including Future Homes Standard type solutions) and services approaches to achieve the same goals.

This updated version of the guide uses analysis carried out in March 2023 using SAP 10.2 software.

We are so grateful for the time and input given by so many people and organisations to bring this document to fruition. It represents collaboration across the sector and the supply chain at its very best.

The UK is going through a Green Industrial Revolution. These new regulations, reflected in this guidance are a step change for us all, but one we can achieve, building homes and communities that work well for customers and residents.

**Ed Lockhart**

CEO Future Homes Hub

## Contents

<b>Foreword</b>	<b>p02</b>
<b>Purpose of the guide</b>	<b>p03</b>
<b>Why read this guide?</b>	<b>p04</b>
<b>Key changes</b>	<b>p05</b>
<b>Meeting the new Part L regulations</b>	<b>p06</b>
- Overheating and Approved Document Part O	p07
<b>The Specifications</b>	<b>p09</b>
<b>Structure of the example solutions page</b>	<b>p10</b>
- Example solutions for compliance: End Terrace House	p11
- Example solutions for compliance: Mid Terrace House	p12
- Example solutions for compliance: Detached House	p13
- Example solutions for compliance: Room in Roof House - semi detached	p14
<b>Looking ahead and The Future Homes Standard</b>	<b>p15</b>
<b>Technical considerations:</b>	
- Illustrating the interaction with other Approved Documents	p16
- Thermal bridging	p17
- Thermal bridging and the notional dwelling	p18
- Ventilation	p19
- Photovoltaics	p20
- Low carbon heat source ready and Waste water heat recovery (WWHR)	p22
- Heat pumps	p23
- Heat pumps - design and installation	p25
- Direct electric and District / Communal heating	p26
- Delivering the designed performance	p27
- Potential causes of poor performance	p28

## Contents continued

- The BREL and Photographic evidence reports	p29
- Example pages from a photographic evidence report	p30
- Grid infrastructure	p31
- U-values for construction elements	p32
- House type and modelling assumptions	p34
- Thermal bridging assumptions	p36
- ADL table 1.1 and Future Homes consultation	p37
<b>Glossary</b>	<b>p38</b>
<b>References</b>	<b>p39</b>

## Purpose of the guide

This guide is intended to help housebuilders, designers, and others involved in the development of new homes to understand the 2021 changes to Approved Document L – Conservation of fuel and power in new dwellings in England (ADL 2021). The guide explains the main implications of the changes and the interaction with other Building Regulations including Approved Document O - Overheating (ADO 2021).

The guide gives examples of some typical homes outlining a combination of measures that are achievable with masonry construction to give a broad understanding of the specifications that may be adopted as a **starting point** for good design.

This is only a general guide and there is no obligation to adopt any of the options given. You should always check with the Building Control Body that your proposals comply with all the requirements of the Building Regulations.

## Why read this guide?

This guide is intended for housebuilders, designers and others involved in the development of new homes in England. It uses examples of possible solutions for typical house types to help explain the main changes to Approved Document L (ADL 2021) it introduces the technologies and techniques which should be considered and describes the new evidence requirements for demonstrating compliance.

The changes to these regulations, which came into force in June 2022, are the first for eight years, but they will be followed by another round of significant changes in 2025.

The transitional arrangements for ADL 2021 only apply to homes where building work has commenced on each individual plot before 15<sup>th</sup> June 2023. This is significant as previous ADL changes could be avoided if work had started on a site. With ADL 2021 the new regulations apply to any plots that have not started.

The new regulations will encourage good low-energy design, improving both the fabric and services, to make homes more comfortable to live in, reduce running costs and drive down carbon emissions whilst also future proofing the home. Energy modelling of a typical semi-detached home suggests a saving of circa £170 - £370 per year on heating and hot water costs\*, compared with the same home built to 2013 regulations.

It is very unlikely that a house type developed to comply with the previous regulations will pass now without any modifications or amendment. It is also unlikely that a home designed without timely and specific thought on energy performance and overheating considerations will comply economically.

Competent overheating and energy advice with preliminary energy modelling (SAP) of potential solutions would be advisable before designs are submitted for planning approval.

This means that energy design needs to be embedded much earlier in the design process. Engaging an energy assessor, or advisor, to provide practical and cost-effective decisions on specifications to assist with compliance, will help.

Emerging themes are:

- walls and floors are likely to be thicker;
- new equipment, services and renewables installed and correctly commissioned;
- construction details will need to be carefully considered and accurately followed on site with some photographed during construction;
- complex forms and features will require very close attention to avoid creating issues;
- greater implications for the orientation of a home;
- glazed areas may reduce, or introduction of shading, with more openable windows to mitigate overheating, increased cill height on upper floors;
- the specification of key elements of the home will be recorded and passed to the homebuyer.

The interactions between Approved Document Part L (ADL) and other the Approved Documents has increased and needs to be well understood and considered as the energy, overheating and ventilation strategies are being developed. Each cannot be considered in isolation.

For example: the requirements of Approved Document Part O (ADO) (concerned with overheating mitigation), had an impact on the minimum window opening height and may have an impact on the size and disposition of windows. ADB (concerning fire safety) may impose a maximum opening height and there may be planning requirements set for daylighting or noise mitigation. Changes in window design may then impact ADL which is sensitive to the potential heat gains and losses through the glass.

Industry bodies, including those representing the timber and masonry sectors, are also working to bring reliable and tested construction 'systems' and details into the public domain together with best practice advice that accounts for fire safety, acoustics, thermal performance, structural and buildability simultaneously.

\* Depending on the specification and using October 2022 Price Cap tariffs.

## Key Changes

### Fabric and services

- Minimum level of thermal performance of the fabric (TFEE) has improved by circa 13%;
- Overall carbon emissions from the dwelling (TER) are reduced by circa 31%;
- A new primary energy target has been added (TPER);
- Energy design (Part L) must be integrated into the early dwelling design and modelled before submitting for planning.

### Overheating - generally (Pages 7, 8)

- New requirements to ensure that homes do not overheat as a result of solar gains or inadequate ventilation;
- New Approved Document O (ADO) provides two methods for demonstrating compliance: the simplified method or dynamic thermal modelling;
- Potentially significant design implications;
- Strongly recommend fully understanding the implications of ADO before developing solutions to comply with Part L.

### Overheating - in locations where noise or pollution may be an issue (Page 7)

- An estimated 30% of new dwellings are built in locations where opening windows at night for purge ventilation may not be desirable due to outside noise or pollution, such as in cities or near main roads;
- For ADO compliance, these homes will have to be assessed using dynamic thermal modelling and incorporate alternative methods for removing excessive heat;
- A specific FHH 'where to start' guide on ADO is available [here](#).

### Heating and hot water (Page 23)

- New homes need to be ready for low carbon heat;
- ADL can be met with a range of heating technologies (including gas boilers), but the new home must be able to easily switch to low carbon technology (for example, heat pumps) in the future;
- Space heating must operate at a maximum of 55°C which means larger radiators or underfloor heating.

### Thermal bridges (Pages 17, 18)

- Account for 15-50% of heat losses through the fabric of a new home;
- To meet the TFEE, it is no longer feasible to assume a default  $\psi$ -value;
- Heat losses from thermal bridges need to be accurately accounted for;
- Designers must generally incorporate recognised details that have modelled thermal bridging  $\psi$  values, or commission  $\psi$  values to be calculated for a particular detail;
- The energy assessor must calculate the heat losses at these bridges;
- The builder must follow the construction details closely on site.

### Reporting evidence of compliance – the BREL report (Pages 29, 30)

- ADL requires the creation of an 'as built' record of the construction and the heating and ventilation systems installed – called the BREL report;
- Generated automatically from the SAP software and highlights any differences between the 'design' and 'as built' construction;
- Must be signed by the SAP assessor and the developer;
- Must be submitted to the building control body and provided to the home buyer.

### Photographic evidence of construction quality (Page 30)

- New requirement of ADL to provide photographic evidence of key construction details for each house. To be submitted alongside the BREL report;
- Examples include: foundations/ substructure and ground floor; external walls; roof; openings; airtightness; building services.

### Grid infrastructure (Page 31)

- New developments using heat pumps, PV, and / or electric vehicle charging need to carefully consider connections to the grid infrastructure to ensure capacity is / will be available;
- Need to follow a process to establish which consents are needed and which network operator to approach.

## Meeting the new Part L regulations

There are now four components to the compliance process:

- **Demonstrating that design doesn't exceed:**
  - **the target fabric energy efficiency rate (TFEE);**
  - **the target emission rate (TER);**
  - **the primary energy target (TPER);**
- **Providing evidence of compliance 'as-built'** (including photos of construction details and important components to building control and the home buyer).

The Approved Documents which contain and outline the new building regulations are technically 'Statutory Guidance' and have a legal status. They use technical and legalistic language and the supporting explanatory, or guidance notes, of previous documents are no longer included.

Changes have been made to the 'transitional arrangements' to help bring houses in the pipeline up to the current standards more quickly.

The new regulations apply to all new homes from 15<sup>th</sup> June 2022, unless the development has a building notice or an initial notice has been given to, or full plans deposited with, a local authority before 15<sup>th</sup> June 2022 and provided that the building work has started **on each plot** before 15<sup>th</sup> June 2023. Note: previous Part L changes could be avoided if work had started on **site**. With Part L 2021, the new regulations apply to any plots that have not started.

New homes warranties are provided by organisations like the NHBC and the process for having defects remedied is clearly outlined by each of the warranty providers.

### Demonstrating compliance at the design stage

Design compliance is carried out via a SAP assessment, as in previous editions of Approved Document Part L (ADL).

The compliance targets are set by using reference values applied to the fabric elements, thermal bridging details, ventilation, airtightness and heating technology (see table 1.1 of ADL 'Summary of notional dwelling specification for new dwelling' - a copy of the table is shown on page 37).

Designs do not have to follow the reference values and some flexibility can be achieved by trading improvements in some areas to compensate for reduced performance in others. For instance, reducing heat losses by improving the airtightness, or wall U-values could allow larger areas of glazing or a worse performing floor construction.

There are however, minimum standards known as 'backstops' for each element which must be met.

### Demonstrating as-built compliance

The new regulations have strengthened the requirements for demonstrating compliance for the home 'as-built'. To show that the home has been built as intended, in the design evidence of construction needs to be submitted to the building control body and the householder. This takes two forms: the Building Regulations England Part L compliance report (BREL report) and a photographic record of sample construction details. See pages 29, 30.

## Overheating and Approved Document Part O

A new Approved Document Part O (ADO) has been introduced in the 2021 edition of the building regulations.

The intention is to protect the 'health and welfare of occupants' by reducing the likelihood of overheating.

The regulations aim to do this by two means:

- **Limiting unwanted solar gains in summer;**
- **Providing adequate means of removing excess heat through ventilation.**

Both of these provisions require analysis of window glazing areas and opening areas as well as some consideration of the orientation of the most glazed façade of the house. Other factors that contribute to overheating will also need to be considered including whether the home has cross-ventilation, where it is geographically located and whether it receives heating and/or hot water from communal heating systems.

A further consideration is the ability of the householder to realistically use open windows for removing excess heat. An estimated 30% of new dwellings are built in locations where opening windows at night is not desirable due to outside noise or pollution concerns. The regulation requires that these homes are assessed using dynamic thermal modelling and incorporates alternative methods that do not rely on window opening.

There is an 'interaction' with Approved Document Part L because solar gains can be useful in winter to reduce the amount of space heating required and these gains are accounted for in the SAP calculation. Whereas reducing summer overheating by limiting glazing areas will impact winter solar gains and therefore increase the need for space heating.

See also page 16 "Illustrating the interaction with other Approved Documents".

There are two methods for 'demonstrating compliance' with the regulations:

- **the simplified method;**
- **the dynamic thermal modelling method.**

The simplified method is far from simple: it requires some complicated calculations, measurement and/or interpretation of manufacturer's data and reference to various appendices and calculating tools. The dynamic thermal modelling method requires simulation software, that would normally be used on large urban projects or non-domestic buildings, to be applied by a competent modeller using CIBSE's TM59 method.

Irrespective of the chosen method there are some physical constraints on window design and operation that must be adopted for upper floor windows and where the finished floor level is more than 600mm above ground level. The ADO advises that the window must have the opening positioned a minimum of 1100mm above the floor or have guarding to the same level. Except for means of escape windows which can have a build tolerance of +0 / -100mm.\*

The house types used in this guide were assessed against ADO using the simplified method and the glazing areas, and the number of opening casements needed to be altered to comply. In general, terraced and semi-detached homes in developer's standard portfolios may fail to achieve the ventilation areas. Detached homes are more likely to exceed the glazing limits, i.e. fail the limiting solar gains test, especially if the majority of glazing is on the west side. Using the simplified method, the requirements are particularly onerous for west facing glazing.

A specific FHH 'where to start' guide on ADO is available [here](#).

\* A 'Questions and Answers' document has been published by DLUHC to help with interpretation of the ADO. Available [here](#).

## Guarding height

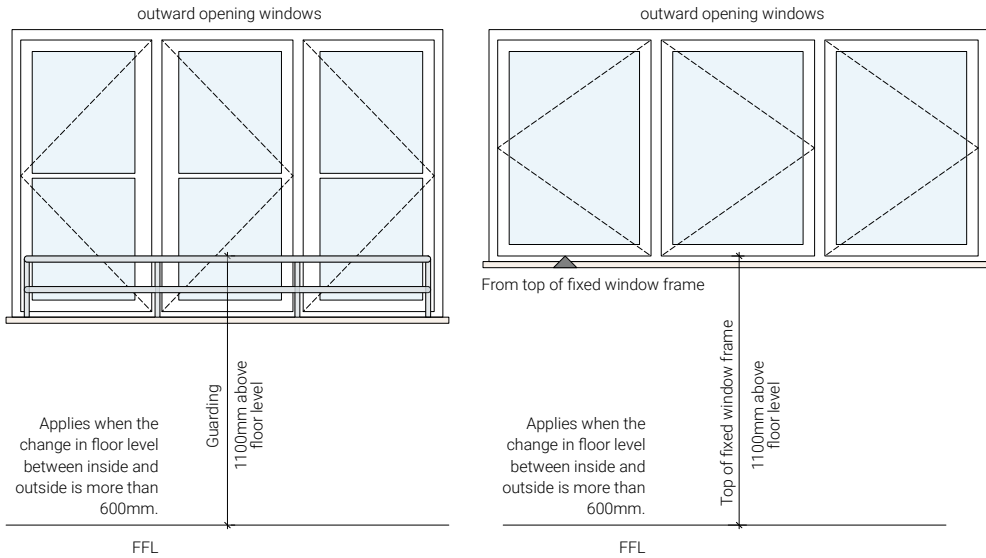

## Guarding arrangements

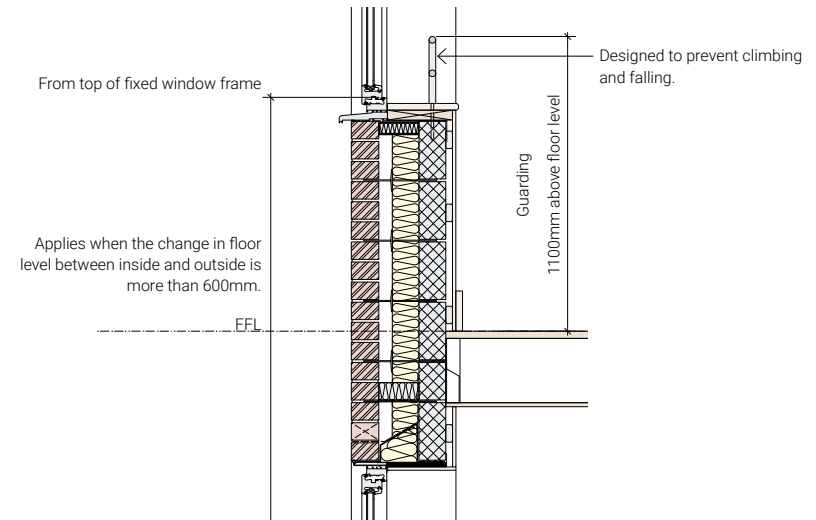

## 650mm window opening limit assumption

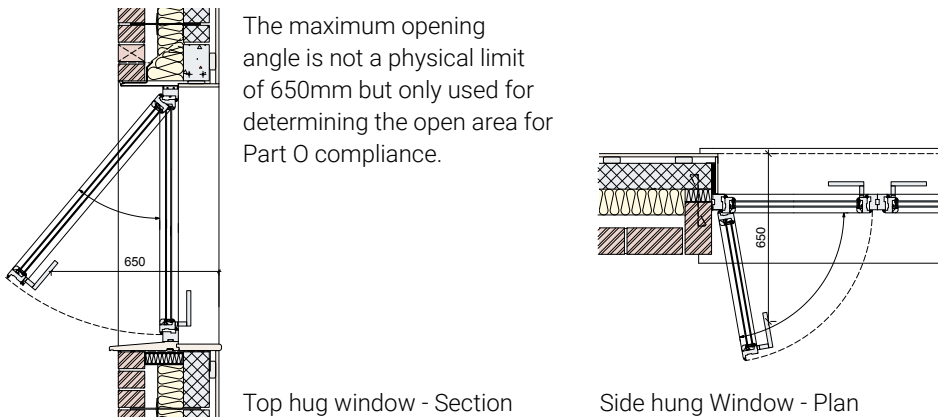

The diagrams on this page show how new Approved Document Part O will impact on the design of windows and façades that will subsequently influence Approved Document Part L considerations.

In summary, the important changes include:

- 1100mm height;
- Maximum 650mm opening assumption for purge ventilation calculation.

There is also an interaction here with ADB regulation (fire) where the window opening must be below 1100mm if it is designated for escape.

DLUHC Part O FAQs have clarified a build tolerance of +0 / -100mm for means of escape windows. Available [here](#).



## The specifications

Three specification approaches have been adopted based on: 1) the common practice 100mm cavity; 2) the 2021 notional dwelling elements; 3) the Future Homes Standard fabric.

There are a vast number of permutations and combinations of specifications and technologies. In order to draw out key themes, simplify presentation and provide a starting point to develop further with an energy assessor and suppliers/manufacturers, a few principles have been applied.

Once the TFEE has been met through appropriate fabric measures, a limited range of heating options have been illustrated, with solar PV and / or waste water heat recovery (WWHR) used to meet the TER and TPER. Where a hot water cylinder is present, a PV diverter can also be used to help meet the TER and TPER, especially in cases where roof area for PV is limited.

The amount of PV is quoted in kWp for an east or west facing roof with little overshadowing. The approaches to meeting TFEE are the same regardless of the heating technology. In the examples with gas-heating, other renewable energy or heat recovery sources are required. Demonstrating DER compliance with an electrical low carbon heat (for instance and air source heat pump) is straightforward, although the primary energy, DPER can become the limiting factor.

Thermal bridging losses are significant and a combination of published Psi values have been used throughout. See page 36.

### 100mm cavity

In this set of examples the starting point has been to try and maintain the standard 100mm cavity width that has been common practice.

The tables illustrate how the new ADL will impact on current practice and these should be compared with examples illustrated in the second and third specification approaches so that the developer or

builder can gauge the benefits and disadvantages of continuing with fairly standard wall build-ups.

However, with only two years to the implementation of the proposed 2025 Future Homes Standard, developers and builders should view the 2021 solutions as steps towards the more challenging 2025 regulations and consider the specification approaches below.

### 2021 notional dwelling

The notional dwelling is the same shape and size as the design actual dwelling, with an upper limit on the glazed area of 25% of floor area. Broadly, the use of the notional dwelling elements in the actual design typically results in compliance with the TFEE, TER and TPER. It is anticipated that many homes will use the 2021 notional as the starting point for design.

Our specification is closely based on, rather than strictly using, the published 2021 notional dwelling element (see page 37). The wall has a wider cavity and, following feedback from industry, the U-value selected (0.19W/m<sup>2</sup>K) is slightly worse, providing practical solutions for a range of concrete blocks. For windows,

the U-value is also slightly worse at 1.3W/m<sup>2</sup>K as commonly available windows at 1.2W/m<sup>2</sup>K have worse g-values than the notional assumes.

All major thermal bridges use calculated Psi values, some of which are worse, and some better, than the notional assumption (see page 36).

Continuous extract ventilation is used due to the advantages over natural ventilation, as set out on page 19, and to allow an airtightness of less than 5m<sup>3</sup>/h.m<sup>2</sup> as a design assumption which is better than the notional.

### Future Homes Standard fabric (FHS)

Rather than going through two changes in short succession, some housebuilders may opt to step directly to the fabric specification indicated for 2025, anticipating and preparing for the 2025 changes, especially in the areas where different details and site practice will be needed.

The draft 2025 notional dwelling has a wall U-value of 0.15 W/m<sup>2</sup>K. To achieve this U-value in masonry construction a wider cavity (more than 150mm) will be needed with most insulation and block combinations.

See the typical wall build-ups and U-values illustrated at Annex A, page 37. The draft 2025 notional building also includes triple glazing and enhanced floor and roof U-values.

Following the same logic as the 2021 notional dwelling, continuous mechanical extract ventilation is used in the illustration, one without and one with heat recovery, rather than natural ventilation.

The FHS provides benefits for both the DFEE and the Dwelling Emission Rate (DER). However, the increased 150mm cavity necessitates: a larger footprint (assuming room sizes are maintained) and different details for: lintels and cills; cavity trays and closers; thought on window positioning and support for the window itself, (including longer fixing brackets and wider sealing tapes etc. to achieve airtightness). A roof U-value of 0.09 W/m<sup>2</sup>K is used.

The upgrade to triple glazing maybe more straightforward, but there are a number of issues still to consider (weight, casement opening, aspect ratio).

## Important general conclusions

The modelling shows that it will be **essential to measure linear thermal bridges**, use published or calculated Psi values for the major thermal bridges (rather than defaults) and document construction with photographic evidence so that the assumptions on thermal bridging made at the design stage can be included in the as-built SAP.

**Caution, the 100mm cavity specification** uses roof and floor build-ups with enhanced levels of insulation, plus good double glazed windows with a high g-value and MEV, to meet the TFEE. There is little opportunity for further improvement. In addition, if any element of the actual dwelling is constructed with worse performance than the design assumption (for instance airtightness) there will be no obvious solution to compensate: the type of heating used or the addition of renewables has no impact on DFEE.

The **2021 Notional Dwelling examples**, which broadly follow the fabric specification of the notional dwelling, **meet the fabric standard with good fabric element performance** and a very achievable air permeability of 4.5m<sup>3</sup>/h.m<sup>2</sup>. These standards for the building fabric (the passive elements that help reduce energy use) are quite demanding, though still some way short of the requirements of Passivhaus.

**Relative energy costs** are presented using October 2022 energy tariffs which **currently show the gas heated solutions being the lowest cost** to the householder. The government has committed to publishing proposals on how to rebalance social and environmental costs away from electricity bills, which **may materially change this outcome**. However, this has been temporarily overtaken by the Energy Price Guarantee.

### Example solutions for compliance: End terrace house

Specification	100mm cavity	2021 Notional dwelling				FHS Fabric	
	1	1	2	3	1	2	
Example	1	1	2	3	1	2	
Wall U-value (W/m <sup>2</sup> K)	0.25	0.19	0.19	0.19	0.15	0.15	
Roof U-value (W/m <sup>2</sup> K)	0.09	0.11	0.11	0.11	0.09	0.09	
Floor U-value (W/m <sup>2</sup> K)	0.11	0.13	0.13	0.13	0.11	0.11	
Window U-value (W/m <sup>2</sup> K)	1.3	1.3	1.3	1.3	0.8	0.8	
Centre pane g-value	0.73	0.73	0.73	0.73	0.50	0.50	
Front door U-value (W/m <sup>2</sup> K)	1.0	1.3	1.3	1.3	1.0	1.0	
Psi-values <sup>1</sup>	Set A	Set A	Set A	Set A	Set B	Set B	
Lintel type <sup>2</sup>	TB	In	In	In	TB	TB	
Air Pressure Test (m <sup>3</sup> /h.m <sup>2</sup> @50Pa)	4	4.5	4.5	4.5	4	3	
Ventilation	MEV	MEV	MEV	MEV	MEV	MVHR	
DFEE Compliance	0%	2%	2%	2%	23%	25%	
Heating	Gas Boiler	Gas Boiler	ASHP	Direct Elec	Gas Boiler	Gas Boiler	
Hot water	Gas Boiler	Gas Boiler	ASHP	DHW ASHP	Gas Boiler	Gas Boiler	
WWHR	No	No	Yes	No	Yes	No	
PV (kWp) <sup>3</sup>	2.01 (6 panels)	2.01 (6 panels)	0	3.35 (10 panels)	0	0	
PV diverter	No	No	No	No	No	No	
DER Compliance	2%	3%	67%	76%	12%	19%	
Carbon Emissions (kgCO <sub>2</sub> pa)	940	930	300	220	840	770	
DPER Compliance	0%	2%	34%	34%	4%	9%	
Energy for SH & DHW (kWh/yr) <sup>4</sup>	5070	4990	1770	3070	3770	3320	
Energy cost <sup>5</sup>	£660	£660	£860	£900	£780	£800	
EPC Rating <sup>6</sup>	91 B	92 A	85 B	87 B	87 B	86 B	

Dwelling modelled here has GIA of 81m<sup>2</sup>

<sup>1</sup> Refer to pages 17, 18 & 36 for more information on thermal bridging and the Psi-values used in these models.  
<sup>2</sup> TB = Thermally broken or split lintel, In = insulated lintel.  
<sup>3</sup> PV east/west facing, <20% overshadowing, min. 1kWp.  
<sup>4</sup> Total yearly energy consumption for space heating and hot water.  
<sup>5</sup> Illustrative - only for heating, hot water, lighting, and pumps & fans, based on SAP calculated energy use and October 2022 Energy Price Guarantee tariffs and standing charges. See note on relative energy costs on page 10.  
<sup>6</sup> The EPC Rating is currently under review by Government.

Future Homes Hub | Part L 2021 Where to start : Masonry Construction

Important - see also the general conclusions noted on page 10.

**100mm cavity**  
 The 100mm cavity wall's performance is significantly worse than the notional building. Other fabric elements must, therefore, be improved significantly to meet the TFEE overall, including: an air permeability of 4m<sup>3</sup>/h.m<sup>2</sup>; thermally broken or split lintels (TB) and increased roof and floor insulation depths.  
 Whilst the TFEE is met, there is little opportunity for further improvement. Neither is there any compliance headroom should detailing or specifications change on-site. Not a recommended approach.

**2021 Notional Dwelling**  
 With the 2021 notional dwelling fabric performance, the carbon emissions and primary energy requirements can be relatively easily met if a gas boiler is used with an appropriate combination of services and renewable technologies.  
 With an air source heat pump (ASHP), then no PV is required and the DER and DPER comply by a significant margin. Waste water heat recovery (WWHR) has been included to reduce hot water cylinder re-charge times, avoid short cycling of an oversized heat pump, and reduce energy costs, rather than for SAP compliance. The addition of 1kWp PV would bring the energy cost down to £700 (EPC 89B).  
 With direct electric heating, either panel or IR, and a domestic hot water heat pump, the carbon emissions target is quite readily met, with primary energy the limiting factor. Whilst the solution complies with less than 1kWp PV, the addition of PV significantly reduces energy costs (which otherwise would be £1,150 (EPC 80C)).

**FHS fabric**  
 The examples with FHS Fabric show that it is possible to achieve overall compliance without the use of PV. However, the addition of PV would reduce the energy cost. For example, with 1kWp PV installed, costs would reduce to £630 (EPC 91B) for Example 1 and £650 (EPC 90B) for Example 2.

**2013 Regulations**  
 For reference the same home built to Part L 2013 with a gas boiler has an energy cost of £1,030 pa.

SOLUTIONS  
End Terrace

11

### Things to watch out for in SAP 10.2

**Sheltered sides:** The more sheltered sides a dwelling has, the less energy it consumes. However, for dwellings with MEV, when looking at compliance with TFEE, TER and TPER, counter-intuitively the greater the number of sheltered sides the harder it is to comply.

**Thermal bridging:** The lower the Psi-value the better the junction performs and the greater the benefit in SAP. The default values in SAP are very conservative so it is best to avoid using these for the major junctions. See page 17 for further information.

**Showers:** The flow rate of showers makes a big difference to the DER and DPER, with 8 litres/min. being the lowest value recognised in SAP10.2. Altering the number of showers can also affect the DER and DPER (especially with WWHR). Ensure the correct information is included and consider entering the maximum number that might be installed (including customer extras).

## Example solutions for compliance: End terrace house

Specification	100mm cavity	2021 Notional dwelling			FHS Fabric	
		1	2	3	1	2
Example	1	1	2	3	1	2
Wall U-value (W/m <sup>2</sup> K)	0.25	0.19	0.19	0.19	0.15	0.15
Roof U-value (W/m <sup>2</sup> K)	0.09	0.11	0.11	0.11	0.09	0.09
Floor U-value (W/m <sup>2</sup> K)	0.11	0.13	0.13	0.13	0.11	0.11
Window U-value (W/m <sup>2</sup> K)	1.3	1.3	1.3	1.3	0.8	0.8
Centre pane g-value	0.73	0.73	0.73	0.73	0.50	0.50
Front door U-value (W/m <sup>2</sup> K)	1.0	1.3	1.3	1.3	1.0	1.0
Psi-values <sup>1</sup>	Set A	Set A	Set A	Set A	Set B	Set B
Lintel type <sup>2</sup>	TB	In	In	In	TB	TB
Air Pressure Test (m <sup>3</sup> /h.m <sup>2</sup> @50Pa)	4	4.5	4.5	4.5	4	3
Ventilation	MEV	MEV	MEV	MEV	MEV	MVHR
DFEE Compliance	0%	2%	2%	2%	23%	25%
Heating	Gas Boiler	Gas Boiler	ASHP	Direct Elec	Gas Boiler	Gas Boiler
Hot water	Gas Boiler	Gas Boiler	ASHP	DHW ASHP	Gas Boiler	Gas Boiler
WWHR	No	No	Yes	No	Yes	No
PV (kWp) <sup>3</sup>	2.01 (6 panels)	2.01 (6 panels)	0	3.35 (10 panels)	0	0
PV diverter	No	No	No	No	No	No
DER Compliance	2%	3%	67%	76%	12%	19%
Carbon Emissions (kgCO <sub>2</sub> pa)	940	930	300	220	840	770
DER Compliance	0%	2%	34%	34%	4%	9%
Energy for SH & DHW (kWh/yr) <sup>4</sup>	5070	4990	1770	3070	3770	3320
Energy cost <sup>5</sup>	£660	£660	£860	£900	£780	£800
EPC Rating <sup>6</sup>	91 B	92 A	85 B	87 B	87 B	86 B

Dwelling modelled here has GIA of 81m<sup>2</sup>

<sup>1</sup> Refer to pages 17, 18 & 36 for more information on thermal bridging and the Psi-values used in these models.

<sup>2</sup> TB = Thermally broken or split lintel; In = Insulated lintel.

<sup>3</sup> PV east/west facing, <20% overshadowing, min. 1kWp.

<sup>4</sup> Total yearly energy consumption for space heating and hot water.

<sup>5</sup> Illustrative - only for heating, hot water, lighting, and pumps & fans, based on SAP calculated energy use and October 2022 Energy Price Guarantee tariffs and standing charges. See note on relative energy costs on page 10.

<sup>6</sup> The EPC Rating is currently under review by Government.

Important - see also the general conclusions noted on page 10.

### 100mm cavity

The 100mm cavity wall's performance is significantly worse than the notional building. Other fabric elements must, therefore, be improved significantly to meet the TFEE overall, including: an air permeability of 4m<sup>3</sup>/h.m<sup>2</sup>, thermally broken or split lintels (TB) and increased roof and floor insulation depths.

Whilst the TFEE is met, there is little opportunity for further improvement. Neither is there any compliance headroom should detailing or specifications change on-site. Not a recommended approach.

### 2021 Notional Dwelling

With the 2021 notional dwelling fabric performance, the carbon emissions and primary energy requirements can be relatively easily met if a gas boiler is used with an appropriate combination of services and renewable technologies.

With an air source heat pump (ASHP), then no PV is required and the DER and DPER comply by a significant margin. Waste water heat recovery (WWHR) has been included to reduce hot water cylinder re-charge times, avoid short cycling of an oversized heat pump, and reduce energy costs, rather than for SAP compliance. The addition of 1kWp PV would bring the energy cost down to £700 (EPC 89B).

With direct electric heating, either panel or IR, and a domestic hot water heat pump, the carbon emissions target is quite readily met, with primary energy the limiting factor. Whilst the solution complies with less than 1kWp PV, the addition of PV significantly reduces energy costs (which otherwise would be £1,150 (EPC 80C).

### FHS fabric

The examples with FHS Fabric show that it is possible to achieve overall compliance without the use of PV. However, the addition of PV would reduce the energy cost. For example, with 1kWp PV installed, costs would reduce to £630 (EPC 91B) for Example 1 and £650 (EPC 90B) for Example 2.

### 2013 Regulations

For reference the same home built to Part L 2013 with a gas boiler has an energy cost of £1,030 pa.

## Example solutions for compliance: Mid terrace house

Specification	100mm cavity	2021 Notional dwelling			FHS Fabric	
		1	2	3	1	2
Example	1	1	2	3	1	2
Wall U-value (W/m <sup>2</sup> K)	0.25	0.19	0.19	0.19	0.15	0.15
Roof U-value (W/m <sup>2</sup> K)	0.09	0.11	0.11	0.11	0.09	0.09
Floor U-value (W/m <sup>2</sup> K) <sup>7</sup>	0.10	0.12	0.12	0.12	0.10	0.11
Window U-value (W/m <sup>2</sup> K)	1.3	1.3	1.3	1.3	0.8	0.8
Centre pane g-value	0.73	0.73	0.73	0.73	0.50	0.50
Front door U-value (W/m <sup>2</sup> K)	1.6	1.3	1.3	1.3	1.0	1.0
Psi-values <sup>1</sup>	Set A	Set A	Set A	Set A	Set B	Set B
Lintel type <sup>2</sup>	In	In	In	In	TB	TB
Air Pressure Test (m <sup>3</sup> /h.m <sup>2</sup> @50Pa)	5	4.5	4.5	4.5	4	3
Ventilation	MEV	MEV	MEV	MEV	MEV	MVHR
DFEE Compliance	1%	4%	4%	4%	25%	27%
Heating	Gas Boiler	Gas Boiler	ASHP	Direct Elec	Gas Boiler	Gas Boiler
Hot water	Gas Boiler	Gas Boiler	ASHP	DHW ASHP	Gas Boiler	Gas Boiler
WWHR	No	No	Yes	No	Yes	No
PV (kWp) <sup>3</sup>	2.01 (6 panels)	2.01 (6 panels)	0	3.35 (10 panels)	0	0
PV diverter	No	No	No	No	No	No
DER Compliance	4%	5%	68%	84%	12%	17%
Carbon Emissions (kgCO <sub>2</sub> pa)	810	800	260	130	740	690
DPER Compliance	2%	3%	35%	45%	2%	6%
Energy for SH & DHW (kWh/yr) <sup>4</sup>	4420	4370	1480	2490	3280	2930
Energy cost <sup>5</sup>	£600	£590	£770	£710	£730	£760
EPC Rating <sup>6</sup>	93 A	93 A	87 B	91 B	88 B	87 B

*Dwelling modelled here has GIA of 81m<sup>2</sup>*

<sup>1</sup> Refer to pages 17, 18 & 36 for more information on thermal bridging and the Psi-values used in these models.

<sup>2</sup> TB = Thermally broken or split lintel; In = Insulated lintel.

<sup>3</sup> PV east/west facing, <20% overshadowing, min. 1kWp.

<sup>4</sup> Total yearly energy consumption for space heating and hot water.

<sup>5</sup> Illustrative - only for heating, hot water, lighting, and pumps & fans, based on SAP calculated energy use and October 2022 Energy Price Guarantee tariffs and standing charges. See note on relative energy costs on page 10.

<sup>6</sup> The EPC Rating is currently under review by Government.

<sup>7</sup> Same floor build-up as end terrace, but gives lower U-value in mid terrace configuration.

Important - see also the general conclusions noted on page 10.

### 100mm cavity

In the example with a 100mm cavity, the fabric specification shown here is not quite as onerous as for the end terrace, which demonstrates the difference that built form can make. However, a terrace would normally be built to the same specification throughout, so the end terrace specification may therefore need to be used. Alternatively, a specification which can demonstrate compliance by averaging over the terrace as per ADL1 paragraph 1.4 could be proposed.

### 2021 Notional Dwelling

With the 2021 Notional Dwelling fabric performance, the carbon emissions and primary energy requirements can be relatively easily met if a gas boiler is used with an appropriate combination of services and renewable technologies.

With an air source heat pump (ASHP), then no PV is required and the DER and DPER over comply by a significant margin. WWHR has been included to reduce hot water cylinder re-charge times, to avoid short cycling of an oversized heat pump, and to reduce energy costs, rather than for SAP compliance. With the addition of 1kWp PV, energy costs for Example 2 would reduce to £610 (EPC 91B).

With direct electric heating, either panel or IR, and a domestic hot water heat pump, the carbon emissions target is quite readily met, with primary energy the limiting factor. Whilst the solution complies without PV (but with WWHR), the addition of PV significantly reduces energy costs (which would otherwise be £1,050 (EPC 81B)).

### FHS fabric

The examples with FHS Fabric show that it is possible to achieve overall compliance without the use of PV. However, the addition of PV would reduce the energy cost. For example, with 1kWp PV installed, costs would reduce to £580 (EPC 91B) for Example 1 and £600 (EPC 91B) for Example 2.

## Example solutions for compliance: Detached house

Specification	100mm cavity	2021 Notional dwelling			FHS Fabric	
		1	2	3	1	2
Example	1	1	2	3	1	2
Wall U-value (W/m <sup>2</sup> K)	0.25	0.19	0.19	0.19	0.15	0.15
Roof U-value (W/m <sup>2</sup> K)	0.09	0.11	0.11	0.11	0.09	0.09
Floor U-value (W/m <sup>2</sup> K)	0.11	0.13	0.13	0.13	0.11	0.11
Window U-value (W/m <sup>2</sup> K)	1.3	1.3	1.3	1.3	0.8	0.8
Centre pane g-value	0.73	0.73	0.73	0.73	0.50	0.50
Front door U-value (W/m <sup>2</sup> K)	1.0	1.3	1.3	1.3	1.0	1.0
Psi-values <sup>1</sup>	Set A	Set A	Set A	Set A	Set B	Set B
Lintel type <sup>2</sup>	TB	In	In	In	TB	TB
Air Pressure Test (m <sup>3</sup> /h.m <sup>2</sup> @50Pa)	3.5	4.5	4.5	4.5	4	3
Ventilation	MEV	MEV	MEV	MEV	MEV	MVHR
DFEE Compliance	0%	1%	1%	1%	21%	23%
Heating	Gas Boiler	Gas Boiler	ASHP	Direct Elec	Gas Boiler	Gas Boiler
Hot water	Gas Boiler	Gas Boiler	ASHP	DHW ASHP	Gas Boiler	Gas Boiler
WWHR	Yes	No	Yes	No	No	Yes
PV (kWp) <sup>3</sup>	4.36 (13 panels)	3.35 (10 panels)	0	4.69 (14 panels)	2.68 (8 panels)	0
PV diverter	No	Yes	No	No	No	No
DER Compliance	2%	1%	57%	66%	3%	16%
Carbon Emissions (kgCO <sub>2</sub> pa)	1260	1280	560	440	800	690
DPER Compliance	1%	3%	14%	14%	2%	6%
Energy for SH & DHW (kWh/yr) <sup>4</sup>	7520	6560	3410	5210	6790	4760
Energy cost <sup>5</sup>	£720	£750	£1,440	£1,490	£770	£970
EPC Rating <sup>6</sup>	95 A	93 A	80 C	81 B	93 A	88 B

*Dwelling modelled here has GIA of 127m<sup>2</sup>*

<sup>1</sup> Refer to pages 17, 18 & 36 for more information on thermal bridging and the Psi-values used in these models.

<sup>2</sup> TB = Thermally broken or split lintel; In = Insulated lintel.

<sup>3</sup> PV east/west facing, <20% overshadowing, min. 1kWp.

<sup>4</sup> Total yearly energy consumption for space heating and hot water.

<sup>5</sup> Illustrative - only for heating, hot water, lighting, and pumps & fans, based on SAP calculated energy use and October 2022 Energy Price Guarantee tariffs and standing charges. See note on relative energy costs on page 10.

<sup>6</sup> The EPC Rating is currently under review by Government.

Important - see also the general conclusions noted on page 10.

### 100mm cavity

The 100mm cavity wall's performance is significantly worse than the notional building. Other fabric elements therefore must be improved significantly to meet the TFEF overall, including: air permeability of 3.5m<sup>3</sup>/h.m<sup>2</sup> and increased roof and floor insulation depths.

Whilst the TFEF is met there is little opportunity for further improvement. Neither is there any compliance headroom should detailing or specifications change on-site. Not a recommended approach.

### 2021 Notional Dwelling

With the 2021 Notional Dwelling fabric performance, the carbon emissions and primary energy requirements can be met if a gas boiler is used with an appropriate combination of services and renewable technologies. However, depending on the design of the dwelling, finding appropriate roof space for the required number of PV panels might become a limiting factor. Adoption of a PV diverter (if a hot water tank is specified) would assist this. This is illustrated in Example 1, which would otherwise require WWHR and more PV in order to comply.

With an air source heat pump (ASHP), no PV is required and the DER and DPER over comply by a significant margin. WWHR is included to reduce hot water cylinder re-charge times and to avoid short cycling of an oversized heat pump. With the addition of 2kWp PV, energy costs for Example 2 would reduce to £1,140 and EPC rating improve to 85B.

With direct electric heating, either panel or IR, and a domestic hot water heat pump, the carbon emissions target is quite readily met, with primary energy the limiting factor. To reduce energy cost (which would otherwise be £1,640 (EPC 78C)), more PV is included than is required for compliance.

### FHS fabric

FHS Fabric Example 1 shows that, even with an extremely good fabric specification, PV is still required in a gas heated detached house with MEV to achieve overall compliance. Example 2, with MVHR, does not require PV for compliance (but does need WWHR). However, the addition of PV would reduce the energy cost. For example, with 2kWp PV installed, energy costs would reduce to £700 (EPC 93A); with 3kWp PV, energy costs would be £600 (EPC 95A).

## Example solutions for compliance: Room in the roof house - Semi detached

Specification	100mm cavity	2021 Notional dwelling			FHS Fabric	
	1	1	2	3	1	2
Example	1	1	2	3	1	2
Wall U-value (W/m <sup>2</sup> K)	0.25	0.19	0.19	0.19	0.15	0.15
Roof U-value (W/m <sup>2</sup> K) <sup>7</sup>	0.11	0.16	0.16	0.16	0.11	0.11
Floor U-value (W/m <sup>2</sup> K)	0.11	0.13	0.13	0.13	0.11	0.11
Window U-value (W/m <sup>2</sup> K)	1.3	1.3	1.3	1.3	0.8	0.8
Centre pane g-value	0.73	0.73	0.73	0.73	0.50	0.50
Front door U-value (W/m <sup>2</sup> K)	1.0	1.3	1.3	1.3	1.0	1.0
Psi-values <sup>1</sup>	Set A	Set A	Set A	Set A	Set B	Set B
Lintel type <sup>2</sup>	TB	TB	TB	TB	TB	TB
Air Pressure Test (m <sup>3</sup> /h.m <sup>2</sup> @50Pa)	4	4.5	4.5	4.5	4	3
Ventilation	MEV	MEV	MEV	MEV	MEV	MVHR
DFEE Compliance	0%	2%	2%	2%	18%	20%
Heating	Gas Boiler	Gas Boiler	ASHP	Direct Elec	Gas Boiler	Gas Boiler
Hot water	Gas Boiler	Gas Boiler	ASHP	DHW ASHP	Gas Boiler	Gas Boiler
WWHR	Yes	Yes	Yes	No	No	No
PV (kWp) <sup>3</sup>	2.68 (8 panels)	2.68 (8 panels)	0	2.68 (8 panels)	2.01 (6 panels)	0
PV diverter	No	No	No	No	No	No
DER Compliance	2%	4%	61%	61%	4%	12%
Carbon Emissions (kgCO <sub>2</sub> pa)	1190	1170	470	470	1170	1060
DPER Compliance	1%	3%	23%	15%	2%	2%
Energy for SH & DHW (kWh/yr) <sup>4</sup>	6500	6400	2870	4320	6130	4650
Energy cost <sup>5</sup>	£740	£730	£1,250	£1,370	£770	£960
EPC Rating <sup>6</sup>	93 A	93 A	81 B	81 B	92 A	87 B

*Dwelling modelled here has GIA of 113m<sup>2</sup>*

<sup>1</sup> Refer to pages 17, 18 & 36 for more information on thermal bridging and the Psi-values used in these models.

<sup>2</sup> TB = Thermally broken or split lintel; In = Insulated lintel.

<sup>3</sup> PV east/west facing, <20% overshadowing, min. 1kWp.

<sup>4</sup> Total yearly energy consumption for space heating and hot water.

<sup>5</sup> Illustrative - only for heating, hot water, lighting, and pumps & fans, based on SAP calculated energy use and October 2022 Energy Price Guarantee tariffs and standing charges. See note on relative energy costs on page 10.

<sup>6</sup> The EPC Rating is currently under review by Government.

<sup>7</sup> Roof cassette U-value.

Important - see also the general conclusions noted on page 10.

Overall, for the room-in-roof house, the specifications required to achieve compliance are more onerous than for the terraced houses, with all specifications shown here requiring roof cassettes, thermally broken or split lintels (TB) and PV. Due to the dormer there is also a reduced roof area suitable for PV panels which may become a constraint depending on which direction the dwelling is orientated.

### 100mm cavity

The performance of the 100m cavity wall is significantly worse than the notional building. Other fabric elements must therefore be improved significantly to meet the TFEE overall, including: air permeability of 4, and increased roof and floor insulation depths.

Whilst the TFEE is met there is little opportunity for further improvement. Neither is there any compliance headroom should detailing or specifications change on-site. Not a recommended approach.

### 2021 Notional Dwelling

With the 2021 Notional Dwelling fabric performance, the carbon emissions and primary energy requirements can be met if a gas boiler is used with an appropriate combination of services and renewable technologies. However, depending on the design and orientation of the dormer, finding appropriate roof space for the required number of PV panels might become a limiting factor. Adoption of a PV diverter (if a hot water tank is specified) would assist this.

With an air source heat pump (ASHP), no PV is required and the DER and DPER over comply by a significant margin. WWHR is included to reduce hot water cylinder re-charge times and to avoid short cycling of an oversized heat pump. However, the addition of PV would reduce the energy cost. For example, with 2kWp PV, energy costs would be £960 (EPC 87B).

With direct electric heating, either panel or IR, and a domestic hot water heat pump, the carbon emissions target is quite readily met, with primary energy the limiting factor. To minimise energy costs (which would otherwise be £1,530 (EPC 77C)) more PV is included than is required for compliance.

### FHS fabric

The FHS Fabric Example 1 shows that, even with an extremely good fabric specification, PV is still required in a gas heated room-in-roof house with MEV to achieve overall compliance. Example 2, with MVHR, does not require PV for compliance. However, the addition of PV would reduce the energy cost. For example, with 2kWp PV installed, energy costs would be £690 (EPC 92A).

## Looking ahead

Although the precise legislative requirements for the Future Homes Standard are unknown, it is expected that homes will:

- be better insulated and more airtight
- need to be well ventilated - probably with a form of mechanical ventilation
- have space and hot water heating from a low carbon source
- need to be resilient to overheating and other climate related events.

Compliance with the new standards will be challenging for everybody involved in the design, construction, commissioning and certification of new homes.

As well as engaging with new technology and conventions, homes should be:

- spacious and comfortable
- efficient and easy to operate
- robust and resilient

Future homes ought to be desirable and demonstrably better than an existing alternative and designed for householders as well as for meeting national carbon commitments.

The research and modelling of solutions for this guide has revealed that compliance will be increasingly complicated and the processes and agents involved in housing delivery will have to change. The form, shape and appearance of homes will also inevitably change.

It is likely that the complexity of details and junctions, at bay windows, dormers, projections and cut-backs will bring an added challenge for compliance, site management and construction quality. Standardisation and simplicity will be essential.

## The Future Homes Standard

The revisions to the Building Regulations explained in this guide form an interim step in the Government's implementation of the Future Homes Standard. Further revisions to the building regulations in 2025 will set performance and energy efficiency standards that mean homes will be 'future-proofed' with low-carbon heating so that no further energy retrofit work will be needed to enable them to become zero-carbon as the electricity grid continues to decarbonise. New homes will not be built with fossil fuel heating such as a natural gas boiler.

The full technical specification for the Future Homes Standard is currently being developed and will be consulted on in 2023. The Government's 2019 FHS consultation proposed for new homes to be built with at least 75% lower carbon emissions than those built to the 2013 Part L standards. This would mean a typical semi-detached house would emit approximately 3.6 kgCO<sub>2</sub>/m<sup>2</sup>/yr compared to 16.0 kgCO<sub>2</sub>/m<sup>2</sup>/yr for a 2013 home (based on 2021 SAP 10 factors).

The Future Homes Hub considered the implications of delivering the 2025 Future Homes Standard, see [Ready for Zero](#) report available [here](#).

In July 2021 the Future Homes Task Force published a road map to support the industry as it prepares to meet the challenge of decarbonising homes. The Task Force has established a broad set of commitments that embrace place making, housing quality, production and business operations. These are summarised in four areas:

- High-quality homes that are zero carbon ready and sustainable.
- Places and developments that are consistently low carbon, nature-rich, resilient, healthy, well designed and beautiful.
- Production and construction methods that are net zero and sustainable by 2050.
- Businesses operations in line with the Race to Zero: net zero by 2050 with a 50% reduction by 2030.

The work of the Future Homes Hub and its various expert groups springs directly from this initiative.

## Illustrating the interaction with other Approved Documents

There are many overlapping considerations when designing low energy homes. The new overheating regulations add further requirements. To illustrate this, there are a number of Regulations to be aware of when designing a window. To make an accurate design stage energy assessment (the design SAP) the design and energy assessor should consider the following.

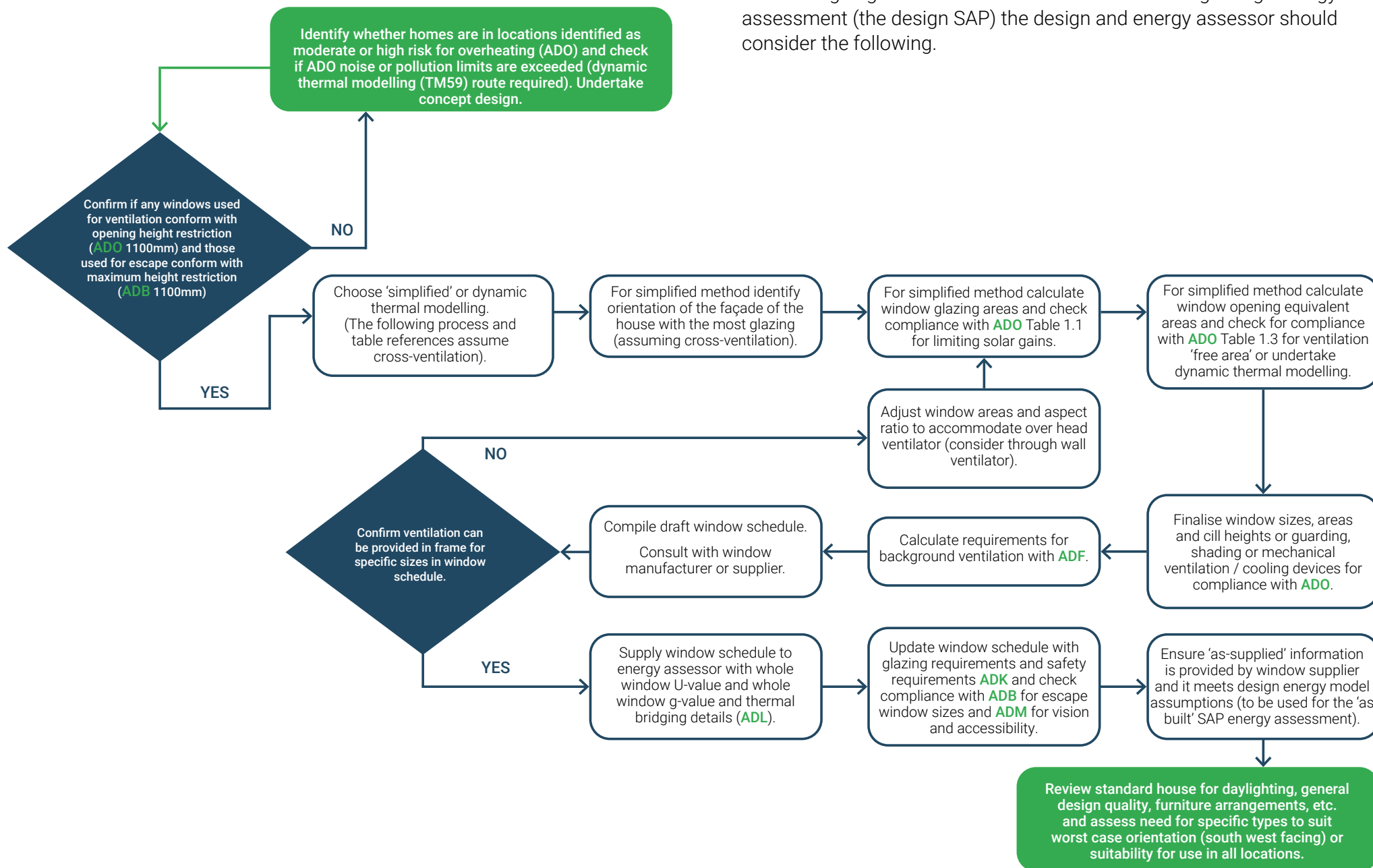



# Thermal bridging

## END TERRACE

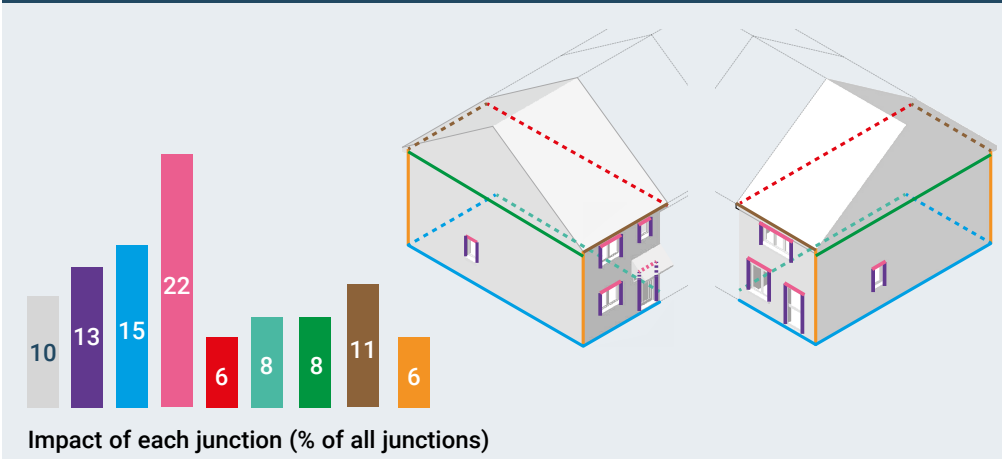

## MID TERRACE

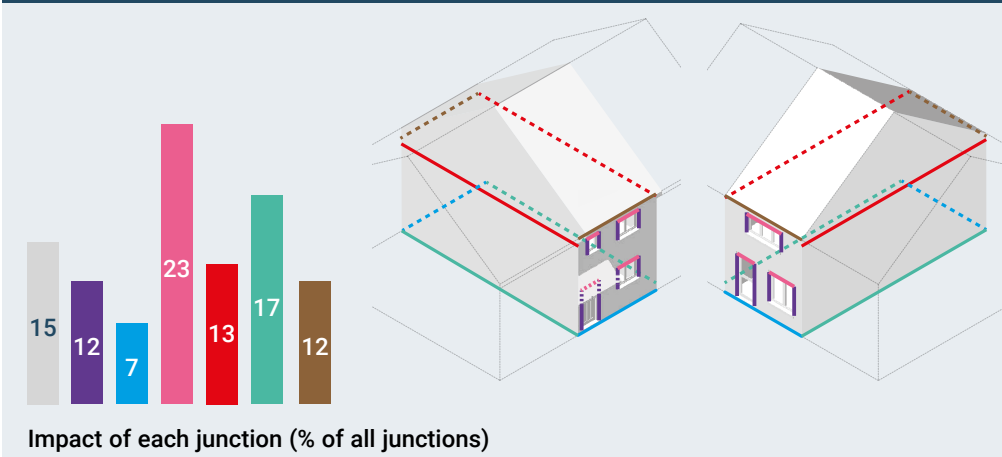

- Ground floor perimeter
- Lintel
- Gable - ceiling
- Jamb
- Corner
- Ground floor - party
- Roof - party ceiling
- Eaves
- All other junctions (sill, intermediate floor, party wall, intermediate party floor)

The modelling throughout this guide assumes that the builder will pay special attention to thermal bridges: selecting appropriate details with modelled Psi values (definition see glossary) and calculating in the SAP tool the linear heat losses that arise from these details. Thermal bridging heat loss makes up 15-50%\* of the overall losses and these have to be accounted for accurately. Generally it will be disadvantageous to assume default values in the SAP model and although technically possible it is no longer feasible in practice to use a default Y-value.

The NHBC Foundation guide to Part L 2013 (NF58) explains thermal bridging and through modelled details provides a good reference and some guidance on potential improvements. [The Zero Carbon Hub guide](#), available [here](#), is also a good source of information.

The term 'accredited details' is no longer used in the ADL and the details that were previously adopted and accredited for thermal bridging for Part L 2006 are no longer valid for current regulations. This is because the thermal bridging losses for a given detail change according to the U-value of the wall, roof or floor, generally increasing as the U-value improves. The ADL refers to 'recognised details' from organisations such as LABC. At the time of writing these details do not exist but work is progressing on a set of details, with LABC support, for masonry and timber constructions.

The Building Alliance has announced the intention to publish a full set of Psi values and Recognised Construction Details by June 2023. See [www.buildingalliance.co.uk](http://www.buildingalliance.co.uk).

In addition to the Psi values being published by the trade associations it is expected that, increasingly, manufacturers will provide standard construction details using their products with calculated Psi values.

\* 15% for calculated and 50% if default used for the home illustrated in this guide.

## Thermal bridging and the notional dwelling

### DETACHED

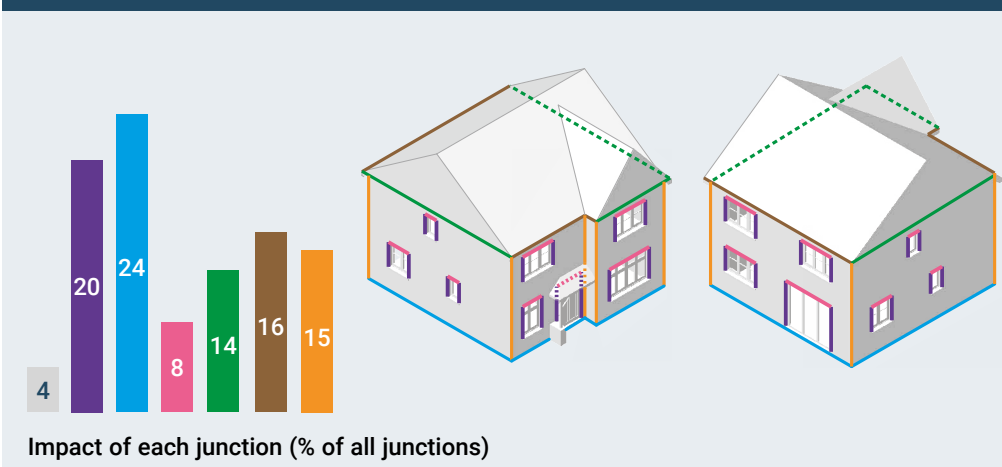

### ROOM IN THE ROOF

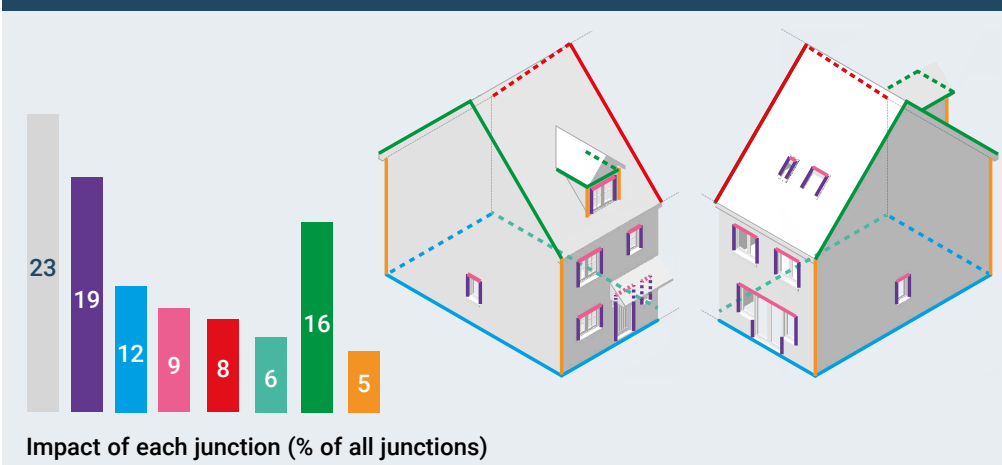

- Ground floor perimeter
- Lintel (RinR: including roof window head)
- Gable - ceiling (RinR: including roof to wall (flat ceiling))
- Jamb (RinR: including roof window jamb)
- Corner
- Ground floor - party
- Roof - party rafter
- Eaves
- All other junctions (sill, corner inverted, intermediate floor. RinR: eaves, intermediate party floor, party wall, roof window sill, roof ridge, flat ceiling-inverted)

The designer needs to know how much heat loss is occurring through thermal bridging. The notional dwelling is not therefore a complete 'recipe' for compliance as the notional dwelling Psi values (which are listed in SAP Appendix R, Table R2) do not have associated construction details and would unlikely match the actual dwelling design. Where the Psi values in the design are worse than those in the notional dwelling it will be necessary to compensate elsewhere, either by improved performance in another thermal bridge or by improvements in another area such as a wall, floor or roof U-value.

Default Psi values (from Table K1 in SAP Appendix K) can be used if a calculated Psi value is not available for a construction detail or material. However, depending on the length of the thermal bridge, quite significant improvements may be required to compensate as the defaults are intended to be more conservative than a calculated value.

Government is relying on the industry to develop thermal bridging details that are modelled by recognised professionals. This puts the small builder at a considerable disadvantage, firstly because they are less likely to have standardised details that are used repeatedly on house types and secondly because the cost of commissioning bespoke thermal bridging models for one-off details is likely to be prohibitive.

See page 36 for the Psi value assumptions for each house type in this guide.

Sourcing good details and constructing them in the correct sequence with the correct thickness and type of materials will be essential, not just for compliance but also for avoiding cold spots and potentially mould growth or degradation of the structure. The information needed to confirm the 'as-built' construction should also document the critical details and evidence their construction. See pages 29, 30.

The illustrations show the relative impact of each junction based on the '2021 notional dwelling' example solutions for compliance shown on p11-14 and the particular dwellings modelled.

## Ventilation

The new homes section of the 2021 edition of Approved Document Part F (ADF) has changed significantly.

Three types of ventilation are used in combination:

- **Whole dwelling ventilation;**
- **Extract ventilation;**
- **Purge ventilation.**

In simple terms **whole dwelling ventilation** provides fresh air from the outside for occupants to breathe and helps remove or dilute pollutants and water vapour. In previous editions this would have been called 'background' ventilation.

**Extract ventilation** is the removal of water vapour, smells or pollutants directly to the outside air to minimise their spread around the rest of the dwelling.

**Purge ventilation** removes high concentrations of pollutants and water vapour and is used intermittently and is required for "pollutants produced by occasional activities (i.e. fumes from painting)". Part O now expands this list to include excess heat.

The ventilation strategy for the dwelling will rely on a combination of all three. However, be aware that the purge ventilation requirements of Part O, to remove excess heat from homes, are likely to be more onerous than from Part F so both documents must be consulted when designing ventilation generally.

Minimum equivalent areas of background ventilators, which provide controllable openings for air entering the dwelling, are specified for use with natural ventilation. Habitable rooms and kitchens for dwellings with multiple floors (houses) require 8000mm<sup>2</sup> in each room unless the dwelling has continuous mechanical extract ventilation where the requirement is halved with a minimum equivalent area of 4000mm<sup>2</sup> required (see ADF Table 1.7 and Para 1.64).

The window specification will need to be considered carefully as some designs or window sizes may not provide the necessary equivalent area from a ventilator that is integrated within the frame. If this is the case a proprietary overhead ventilator or through the wall ventilator might be suitable. However, the former of these will alter the casement sizes in the window (assuming the overall opening is constant) and the measurements of glazing area and equivalent area for purge ventilation in Part O will be affected. For this reason, it is essential that Parts O, F and L are considered together, and not in isolation.

The flow chart at page 16 illustrates a logical sequence of steps to check that all requirements are met. As designers and specifiers become more familiar with the new regulations, and the products to meet them, the solutions may become more intuitive.

Recently, more housebuilders have adopted continuous mechanical ventilation (centralised MEV and decentralised MEV).

It is likely that this trend will continue because the requirements for background ventilators for continuous mechanical ventilation are less onerous so can be met with a wider range of windows.

## Ventilation continued

There may also be concerns about the perceptions of draughts and discomfort created by ventilators that are larger than were previously required.

Continuous mechanical ventilation, when correctly installed and commissioned may well prove to be a more robust solution than a natural ventilation system where the background ventilator that can easily be closed.

The type of ventilation system chosen for the dwelling also depends on the intended and as-built airtightness. Either continuous mechanical extract ventilation (MEV) or mechanical ventilation with heat recovery (MVHR) must be used for all dwellings that are defined as highly airtight.

**Highly airtight dwellings:** Dwellings that achieve one of the following:

1. A design air permeability lower than  $5\text{m}^3/(\text{h}\cdot\text{m}^2)$  at 50Pa.
2. An as-built air permeability lower than  $3\text{m}^3/(\text{h}\cdot\text{m}^2)$  at 50Pa.

For the same level of air permeability, SAP modelling typically gives a Carbon emissions benefit when using continuous mechanical extract ventilation. Where the housebuilder is confident, assuming a lower as-built air permeability improves the fabric energy efficiency.

For these reasons, the example specifications in the guide all assume the use of continuous mechanical extract ventilation. Mechanical ventilation with heat recovery (MVHR) is used as an example in the future homes standard fabric approach.

There are no significant differences in the energy model using centralised or decentralised systems.

For full details refer to 2021 Approved Document Part F.

## Photovoltaics

Photovoltaic panels (PVs) convert solar energy into electricity. PVs are generally about 1m x 1.7m (but larger ones are increasingly being adopted) and are connected in electrical series as an 'array' to achieve a desired energy output. The efficiency of PVs is dependent on orientation; overshadowing; and the angle of the roof on which they are fixed. As they are connected in electrical series, shadowing of just one panel in a string reduces the output from all panels in that string, so care must be taken to ensure all panels have the same illumination levels. Where this isn't possible, for example when some panels are located on one side of a traditional pitched roof and some on the other, either power optimisers or microinverters should be used to avoid the large reduction in energy output that would otherwise occur. The ideal roof angle depends on the location of the home but generally 30° elevation is the optimum in the UK. Solar panels can predictably generate electricity even on cloudy days and from indirect sunlight. They work more efficiently at cooler temperatures, common to the UK.

For the modelling in this guide it has been assumed that a 1m x 1.7m PV panel has a peak output of 335Wp. It is essential to calculate whether the roof can accommodate the amount of PV needed for compliance with Part L. It is, of course, practical to combine PV with other energy saving devices such as waste water heat recovery. However, the marginal cost of adding additional PV panels is relatively low and as the ancillary equipment (meters, inverters, diverters etc) is already required, it makes sense to size the system for practical purposes and cost effective operation rather than just the minimum for compliance. Organisations like the Energy Saving Trust (EST) can provide advice.

## Photovoltaics continued

As PVs use the sun's energy, they may generate surplus energy during the day when demand is low but may also supply insufficient energy when demand is high in the evenings.

To help balance this, surplus energy can be exported or 'diverted' to a storage system within the house. This could be an electrical store (a battery) or a thermal store such as an immersion heater in a hot water cylinder. The latter is an attractive option if the house has a heat pump because heat pumps operate less efficiently when heating hot water so will benefit from the supplementary energy from PVs. Increasingly, control systems will become more sophisticated in directing electrical energy to the best use within the home which could be to the appliances and/or heat pump running off the home's wiring; to the storage system; or to export to the grid. These controls will account for different charging tariffs, when these become available.

Whilst PV installations are becoming quite common there are important safety and performance considerations:

- The equipment and installer must be MCS certified (to enable the householder to claim smart export guarantee payments from their energy supplier) and be experienced in designing/installing/commissioning this equipment
- Wind loading calculations will need to be done
- Panels, fixing kit and other electrical components (isolators, cables, connectors, meters etc) must be appropriately fire-rating, such as  $B_{ROOF}(t4)$ , and meet the relevant standards.



Photovoltaics can be integrated with the roof. Image provided by: Viridian Solar.

## Low carbon heat source ready

Although this guide shows three different approaches to heating, where a gas boiler is used it should be noted that ADL now requires the heating system to be 'readied' for a low-carbon heat source, for example a heat pump or from a district heating system.

This means that homes with a gas heating system should be designed with radiators or under-floor heating to work at a maximum flow temperature of 55°C. This new measure is intended to ensure that condensing boilers work efficiently but also 'future-proofs' homes for a change over to heat pumps which work more efficiently with a lower heating distribution temperatures.

Additionally, best practice would be to 'future-proof' by ensuring that there is room to accommodate a large hot water cylinder for when homes convert from a combination boiler to heat pump operation in the future.

### Other technologies

To avoid overcomplicating the guidance, only a limited range of technologies have been illustrated to provide a starting point for the discussion with an energy assessor. The following technologies are all worthy of consideration from a compliance, running cost reduction and householder satisfaction perspective, including:

- Photovoltaic panels (PV)
- PV diverters
- Batteries (to store PV generated electricity)
- Waste water heat recovery (WWHR)
- Heat pumps
- Infra-red heating
- Communal heating
- Solar thermal
- Flue gas heat recovery (FGHR)
- Heat storage
- Phase change thermal stores
- Smart cylinders
- Smart controls
- Low-flow showers

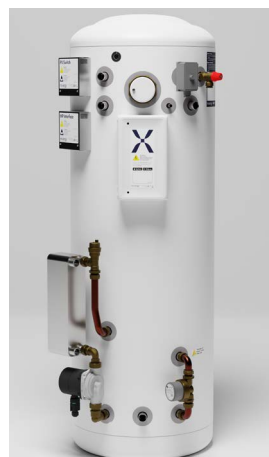

'Mixergy' smart hot water tank

## Waste water heat recovery (WWHR)

WWHR units recover heat from a shower's outgoing drain water and use it to warm up the incoming cold water which supplies the shower and/or the incoming feed of a hot water tank or combi boiler.

WWHR units come in two basic types:

- vertical units - usually installed in the floor below the shower (next to soil and vent pipe) and do not require any maintenance
- horizontal units - more costly than vertical units and require cleaning

Vertical units are considered to be more efficient than horizontal units.

Systems typically take the form of a long vertical copper pipe containing the warm drain water, which runs inside a coil of colder mains water to exchange the heat. WWHR systems are most efficient when this pre-warmed cold is fed to both the shower mixer and the hot water heater. This is called 'balanced flow' and is referred to within SAP as System A. WWHR systems require incoming cold water to run through the unit simultaneously to the water flowing down the drain, as such they only work with showers and not baths.

WWHR technology has been recognised in SAP and used in UK house building since 2009. Systems tend to have a significant service life and rarely fail as they have no moving parts.

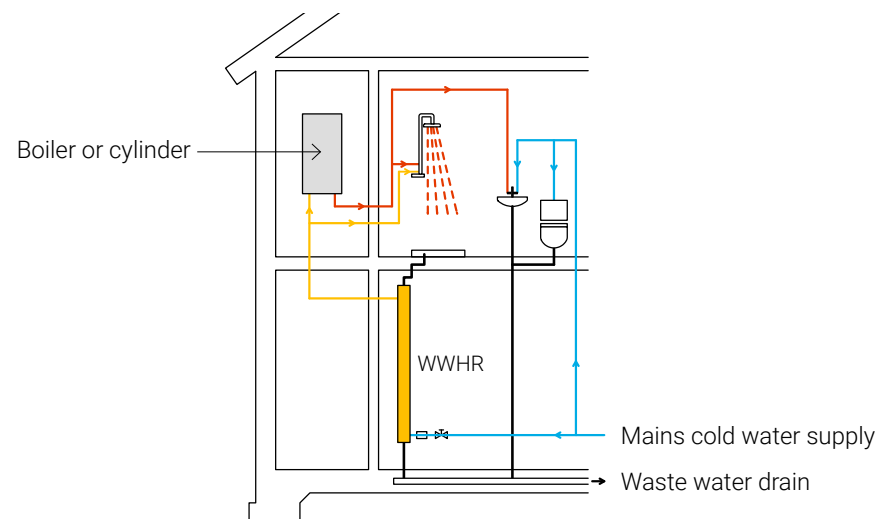

## Heat pumps

Heat pumps make use of the low-grade heat found in the outside air, the ground or bodies of water.

The thermal energy collected from outside is 'consolidated' via a compressor-evaporator cycle and transferred to a home's internal heating system.

This is the same process that is used to extract heat from a refrigerator. Heat pumps can work very efficiently producing 2 to 4 units of thermal energy for each unit of electrical energy used in the process. As electrical devices they also take advantage of the increasing proportion of renewable energy in the national grid.

Specialist advice should be sought at the design stage to ensure that heat pumps integrate seamlessly.

In addition to the common heat pumps described below are: air to air and water source heat pumps.

### Air Source Heat Pumps (ASHPs)

ASHPs use ambient air to heat water to temperatures required for space heating and hot water in a home. They are external units connected to an unvented hot water cylinder within the home and come in two types:

Monoblock

- contain all components in a single unit
- need to be sited close to homes
- do not need an installer with experience in handling refrigerants (F-gas qualifications)

Split

- smaller outdoor units plus an indoor unit (sometimes combined with the hot water cylinder)
- can be installed further from homes - to aid aesthetics or when installed in apartments
- need installer with F-gas qualifications.

Monoblock ASHPs are currently seen as gas boiler replacements and a leading choice for many homes built to the Future Homes Standard.



ASHP in-situ.

Image provided by: Dr. J.Wingfield.

## Heat pumps continued

### Domestic Hot Water Heat Pump (DHW HP)

These are generally integrated with a cylinder as a compact floor standing unit which utilises external air, or warm air within the room, to heat domestic hot water to the required temperature. These could be combined with, for example, a direct electric heating solution such as electric radiators or infrared panels.

### Exhaust Air Heat Pumps (EAHPs)

An alternative to ASHPs, EAHPs are more suited to smaller homes with lower heat demands.

They use air extracted from homes via mechanical ventilation (MEV) systems to produce hot water and sometimes space heating. They are internal units which tend to come with integrated MEV and hot water cylinders.

### Ground Source Heat Pumps (GSHPs)

An alternative to ASHPs, GSHPs are more expensive but may be more appropriate for particularly large homes or clusters of homes and apartments as part of communal schemes.

They use the relatively stable temperature of the ground to heat water to temperatures required for space heating and hot water in homes. This can be done by using shallow buried 'slinky' pipes or boreholes.

They are more efficient than ASHPs because the temperature of the ground is higher than the temperature of the air in winter.

### Refrigerant Global Warming Potential (GWP)

Heat pumps, along with fridges and air conditioning units, are using refrigerants with progressively lower GWPs. The GWP of a gas is the global warming impact, compared with CO<sub>2</sub>, should it be released into the atmosphere. The higher the GWP the more damaging to the environment. Three refrigerants are commonly used in heat pumps: R290 (GWP=3), R32 (GWP 677), R410A (GWP 2,088).



Vaillant Air-to-water domestic hot water heat pump.



Nibe Exhaust Air heat pump.



## Heat pumps - design and installation

This is a specialist activity and there are some important considerations in how the system needs to be designed, installed, commissioned and run, in order to achieve low bills, good levels of comfort and sufficient hot water in homes:

### Design

- Consult a design specialist and run it past the heat pump manufacturer; or ask the manufacturer to design the system;
- Ideally choose a Microgeneration Certification Scheme (MCS) certified heat pump;
- Choose a heat pump with high efficiencies - look at coefficient of performance (CoP) and seasonal performance factor (SPF);
- Choose a heat pump which uses refrigerant with a low Global Warming Potential (GWP);
- Choose a heat pump with a compressor inverter and ensure it is not oversized for its space heating load which would result in short cycling and significantly reduced efficiencies;
- Keep space heating flow temperature as low as possible (max 45°C with 35°C gives better efficiency). However, this has implications on heat emitter sizing;
- Radiators must be sized for this lower flow temperature (they will be larger than those currently used with gas boilers); or use underfloor heating;
- Radiators may need to be fed by larger pipework, so check for coordination issues - especially at pipe bends ;
- Ensure the cylinder is suitable for use with a heat pump and large enough to provide sufficient hot water. Take specialist advice on this;
- For best performance use a cylinder or heat store recommended by the heat pump manufacturer;
- Aim for recharge times to be achieved without use of a direct immersion heater to minimise energy use. Combining with WWHR is beneficial see page 22.
- If the home is close to the coast then corrosion protection measures should be adopted.

- Locate the heat pump unit away from windows and ensure manufacturer recommendations are followed with regards to air flow and maintenance clearances and to minimise vibration and noise;
- Check coordination drawings to ensure heat pump location does not clash with other items. For example, garden tap locations;
- Ensure sufficient user controls are specified which work with the rest of the system and are easy to use and understand.

### Installation

- Ensure installers have been on a manufacturer-specific training course for the chosen heat pump;
- Preferably choose an installer who is MCS certified. If not, use MCS MIS3005-I & D to ensure the installation and design quality;
- Installers must be F-Gas qualified for installing split systems;
- Ensure the whole system is installed by the same person;
- Good QA is necessary to ensure good performance of systems - MCS accreditation should help with this.

### Commissioning

- Ensure the person commissioning the system is suitably qualified;
- Ensure initial set up of controls is likely to lead to good outcomes for the householder - low bills, warm house, sufficient hot water;
- For sites with multiple homes - make sure commissioning settings are pre-approved across the whole site to ensure consistency.

### Handover

- The way the heating and hot water system works should be explained on handover to highlight how to run the system efficiently and achieve lower bills;
- If the householder's previous home had a gas boiler then there are some major differences that should be explained, such as:
  - system not being as responsive;
  - radiators (if installed) feeling cooler to the touch but rooms still reaching a comfortable temperature;
  - using set backs rather than on/off timer to control space heating.

## Direct electric

Heat pumps are very efficient when designed, installed and operated correctly. There are however other alternatives that offer simplicity and lower installation cost, whilst still using electricity as the energy source. Direct electric heating can take many forms including:

- simple radiating panels,
- circuits within a floor screed (under-floor heating),
- infrared panels
- high performance storage heaters or heating coils within an air distribution system.

These technologies cannot match the efficiency of a heat pump, but in a home with very low heating demand, they may present a viable alternative as they do not require a 'wet' heating system. These technologies are inherently simple and reliable and do not require any additional space for the heat pump, boiler or radiators.

In a very low energy home the hot water demand is likely to exceed the space heating demand so there is some merit in thinking about an efficient system for heating hot water that is independent from the space heating. It is also an attractive solution for a small home or apartment where the hot water could be generated by a heat pump that is neatly packaged with the hot water cylinder and is sized appropriately for providing hot water only.

Although less efficient than heat pumps, some direct electric systems require very little maintenance or servicing so, when coupled with an extremely efficient building fabric, cost savings in-use may still be made even if the carbon savings are not as high. The simplicity of operation may also be helpful in some circumstances for example: in some short term rental properties for vulnerable residents where the explanation and demonstration of controls and operation of low temperature heating may be more challenging. Although it is important to consider the risks of potential increased running costs associated with direct electric for these vulnerable groups.

## District / Communal heating

The Committee on Climate Change estimates that around 18% of our heat will need to come from heat networks by 2050 if the UK is to meet its carbon targets cost-effectively.

There are a few different ways to categorise the different types of district heating but it is most common to split them into two categories:

- District Heating (4<sup>th</sup> generation heat networks) distributes usable heat from an energy centre from a range of potential sources including: heat pumps, biomass boilers and combined heat and power generators to domestic and/or non-domestic properties via a network of insulated pipes.
- Ambient Heat Networks (5<sup>th</sup> generation heat networks) distribute ambient heat from the ground or other sources to a network of local heat pumps which are installed in domestic or non-domestic properties. The heat pumps then raise the ambient heat to temperatures which suitable for heating and hot water.

These systems may also include thermal storage to smooth grid demand and allow access to lower rate tariffs. In the run up to the Future Homes Standard in 2025 commercial propositions are likely to mature and become more well known.



Infrared heating panel. Image provided by: Wondrwall.

## Delivering the designed performance

Innovate UK's Building Performance Evaluation Programme, which looked at 76 low carbon homes to assess how well they achieved their performance targets, found that actual carbon emissions from these homes were on average two to three times higher than design estimates.

A comprehensive study by the Zero Carbon Hub in 2014 established many causes ranging from: design assumptions, conventions in modelling tools, laboratory testing conventions, construction, installation, and quality control issues on site and poor commissioning. Occupied homes that were difficult to manage or maintain correctly, were also formed to under perform.

With the wider adoption of lower power heat sources, such as heat pumps, sensitivity to under performance of the fabric, and energy systems, is increased. Whereas the power of a gas boiler meant the home was still warm, albeit using more energy, a heat pump may not be able to compensate for the increased losses during particularly cold periods resulting in cold homes and increased bills.

The 2021 edition of the building regulations does not specifically refer to closing the gap between design and as-built performance but it has strengthened the requirements for demonstrating that the building has been built as intended in the design by requiring evidence of construction see pages 29, 30.

Some likely causes of under performance, which are within the control of the builder, are set out here and, in combination with the requirements for photographic evidence, should be a good starting point for assessing where to focus better design or to enhance site controls, inspection and commissioning.

The photographic evidence provided to the home buyer will be an obvious reference point for a householder that perceives there to be a defect or a performance issue of some kind.

A new role to protect consumer and purchaser interests has also been created, the new homes ombudsman. However, the precise remit of the ombudsman has not yet been defined.

Whilst building inspectors check that building regulations requirements are met on new homes, it is the builders responsibility to ensure new homes are built to the right standards and that the correct information is provided at completion and handover.

Householders and surveyors will increasingly turn to the documentary evidence of construction and actual energy performance compared with the home's EPC to support complaints.

Additionally, the advent of smart heating controls and emerging techniques to measure a home's performance will generate more sophisticated data, rather than simply measuring energy usage, highlighting poor performance more readily.

## Potential causes of poor performance

### Heat loss through fabric (conduction)

- Thermal bridging details not constructed as designed or modelled
- Missing or poorly installed insulation such as leaving gaps and not taping joints
- Poorly injected insulation such as missing areas under cavity trays
- Product substitutions (insulation type/ thickness/ density, concrete blocks with worse lambda value, windows with worse U-value or g-value - rather than that specified in the energy model).
- Timber content (known as timber fraction) not accurately accounted for
- Type and number of wall ties not properly accounted for
- Other thermal bridges or discontinuities in the thermal layer missed or not properly accounted for
- Windows not installed within the wall in the position specified
- Insulation not in intimate contact with the air tightness barrier (allowing thermal bypass)

### Heat loss from ventilation

- Penetrations through air-barrier not sealed or sealed using incorrect products
- Superficial foaming or siliconing of cracks and voids which subsequently fail
- Movement, settlement cracking
- Displacement or damage to air-tightness barrier and tapes
- Distortion or degradation of window seals or closing mechanisms

*Data from the Innovate UK study showed that for 28% of homes the airtightness levels were frequently above the initial as-built result when retested at a later date.*

### Inefficient ventilation systems

- Ductwork not installed as designed
- Substitution of rigid ductwork with flexible
- Ductwork not insulated where required
- Systems not commissioned correctly
- Terminals and inlet/outlet grilles not as designed or specified

### Inefficient heating and hot water systems

- Heat emitters not installed as designed and not balanced
- Boiler or heating system sizing revised (assumes designed correctly in first place)
- Boiler flow and return temperatures too high preventing condensing operation
- High distribution losses in communal systems
- Large storage losses in hot water systems
- Incorrect distribution temperatures
- Oversized heat pumps and boilers causing short cycling
- Controls not installed or programmed as designed
- Commissioning not completed correctly

See also the installation and commissioning issues raised on page 25 for heat pumps.

## The BREL and photographic evidence reports

Evidence of compliance is introduced into the regulations via two reports; the photographic evidence report and the BREL (Building Regulation England Part L) report.

Photos are taken for each dwelling as they are constructed to indicate build quality. They are targeted to show typical details that confirm:

- thermal continuity;
- airtightness detailing;
- what key building services, plant and equipment have been installed;
- pipe and ductwork insulation.

The typical good practice details are listed in the ADL. They are not specified with the intention of being fully comprehensive of all details, limiting the number of photos required. Extracts of a typical report are shown on the next page. Where dimensions are critical, such as window position, a tape measure is included in the photo. The diagram shows the flow of information.

Anyone can take the photos, but they will probably be taken by the builder. The photos need to be digital and should be enabled for geo-location, date and time. When displayed in the report, the photos can have the information displayed on them or adjacent to them, but the production of this information should be autogenerated and not involve manual input. One option of achieving this can be through the purchase of a low or zero cost mobile phone app which will display these details on the photograph.

The photos should then be sent to the SAP Assessor who should review them against the details/specifications, that have been provided for the SAP Assessment for the build, to evidence:

- insulation continuity; and
- that no products have been substituted.

Where necessary, the assessor will make changes to the As-Built SAP (following the SAP Conventions). It is possible that, if changes to the Design SAP are required to reflect As-Built, this could lead to non-

compliance. For example, with the higher fabric requirements, some of the thermal bridges are particularly critical and remediation is costly. Likewise, with these higher standards, finding areas to improve to compensate, after the event, may not be possible. As such, it is critical that the design is accurately reflected on site and, should changes need to be made on site, these are checked with the SAP assessor in advance.

The BREL report is generated by the SAP software and needs to be signed by both the SAP Assessor and the builder to confirm its accuracy. It is the duty of the builder to produce the photographic evidence report, although they may ask the SAP Assessor to do this on their behalf (if the Assessor agrees). Both reports are then provided, by the builder, to both the dwelling owner and Building Control.

Reporting is covered in Appendix B of ADL.

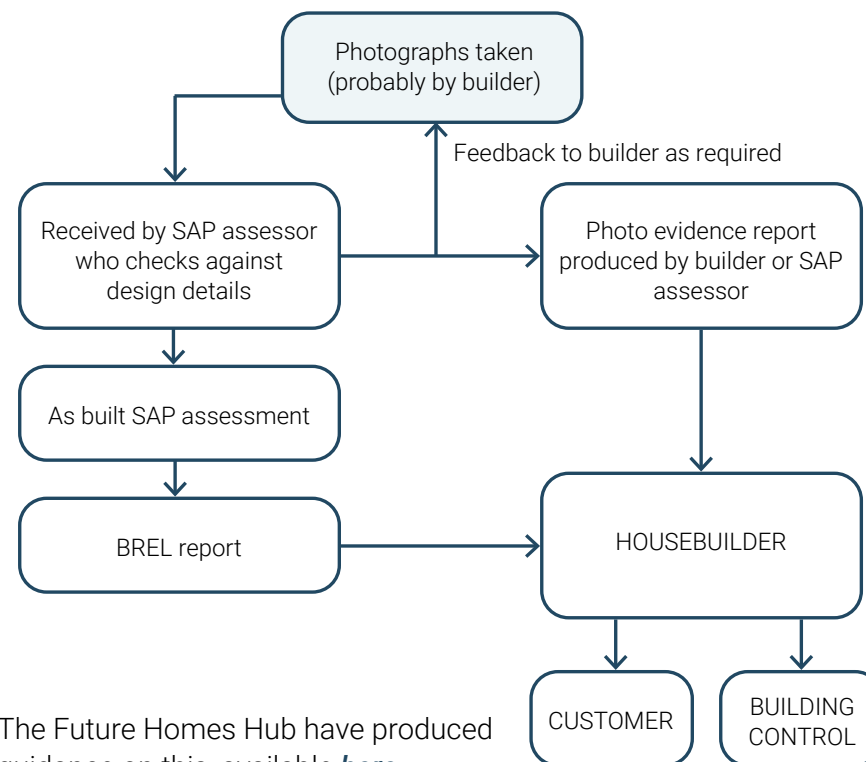

The Future Homes Hub have produced guidance on this, available [here](#).

# Example pages from a photographic evidence report

Photograph Evidence Report			
Property Reference	Example 2	Issued on Date	26/06/2020
Assessment Reference	001	Prop Type Ref	Mid Terraced House
Property	Mid Terraced House, 12, Main Street, Lutterworth, Leics, LE17 4XX		
Assessor Details	Assessor ID		



14/02/2022  
10:30

**2. External walls**

b. Structural penetrating elements (SAP junction reference E1/2)  
Photo reference: P1/2b



14/02/2022  
10:40

**3. Roof**

b. Eaves and gable edges (SAP junction reference E10-E13)  
Photo reference: P1/3b.1

© Elmhurst Energy Systems Limited Registered Office Unit 16, St Johns Business Park, Lutterworth, Leicestershire LE17 4HB

Photograph Evidence Report			
Property Reference	Example 2	Issued on Date	26/06/2020
Assessment Reference	001	Prop Type Ref	Mid Terraced House
Property	Mid Terraced House, 12, Main Street, Lutterworth, Leics, LE17 4XX		
Assessor Details	Assessor ID		



14/02/2022  
11:00

**4. Openings**

a. Window positioning in relation to cavity closer or insulation line (SAP junction reference E4)  
Photo reference: P1/4a



14/02/2022  
11:00

**6. Building services**

a. Plant equipment identification label(s), including make/model and serial number.  
Photo reference: P1/5b.1

© Elmhurst Energy Systems Limited Registered Office Unit 16, St Johns Business Park, Lutterworth, Leicestershire LE17 4HB

## Grid infrastructure

### Grid infrastructure: connecting and registering energy devices

There are some important requirements when a new home is connected to the electricity network if it has any of the following technologies, known as energy devices or energy assets:

- solar photovoltaic (PV)
- heat pump
- electric vehicle (EV) charging point
- battery storage

The energy device must be registered with the company that is responsible for bringing electricity to the property where the device is installed. The network companies need to know how many of these energy assets sit on their networks, in order to effectively manage the extra demand on the system. These companies are known as Distribution Network Operators (DNOs) and the relevant DNO can be found on the Electricity Network Associations website.

DNOs own and operate the networks which carry electricity from the national grid and distribute it to customers or to a boundary point. Each DNO covers a geographical region. Independent Distribution Network Operators (IDNOs) own and operate networks which are connected to DNO networks at a boundary point. They are not restricted by region and can compete to connect and then operate the network anywhere.

### Grid infrastructure: development sites

Contact your DNO or IDNO as early as possible when considering land valuations and acquisitions.

Early conversations can reduce costs and time spent in planning. To ensure an appropriate and cost-effective connection, DNOs and IDNOs need to know a development's:

- maximum number of units on the site
- anticipated electricity load
- information about large, connected devices, especially heat pumps (ideally supply the heat pump type registration number as used in the Energy Network Association's (ena) heat pump database to

allow for infrastructure calculation for use of agreed peak amp draw)

- pairing heat pumps with some form of thermal storage
- EV charge points (EVCPs)
- total PV capacity
- battery storage
- smart technology (such as inverters) or limitation devices
- flexible connections and active network management (ANM) schemes
- sharing connections with other sites and customers in the area

### Help and support

For information on how to register devices and whether consents are required prior to installation refer to '[How to register energy devices in homes or small businesses](#)' guidance available [here](#).

For more information about whole site considerations contact microgeneration suppliers, heat network partners or planning and utility consultants.

### Approved Document Part S - Provision of EV chargers

Part S is a detailed document that explains the number of EV charge points required (typically one per dwelling, but not always), their position, the appropriate standards for chargers and the detailing of cable routes.

Advice is also available from the Independent Networks Association together with guidance on supply requirements. In most cases a 100A single phase service will be sufficient for up to 7.2kW (32A) EVCP demand at a domestic dwelling.

Part S takes effect from 15<sup>th</sup> June 2022. Provided work has started on site before 15<sup>th</sup> June 2023, it will not apply to projects with a building notice, full plans application or initial notice submitted before that date.

Part S applies on a site-wide basis, it does not apply on a dwelling by dwelling basis like Part L, F and O.

# U-values for construction elements

## U-values: cold roof and ground floor

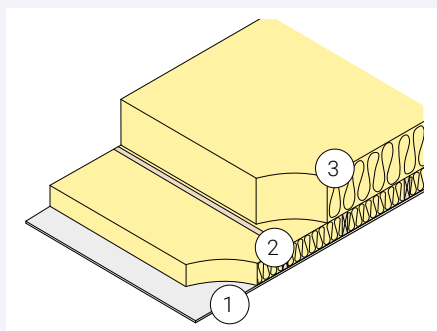

### Roof: cold roof

1. Plasterboard
2. Mineral wool insulation between joists ( $\lambda = 0.044 \text{ W/mK}$ )
3. Mineral wool insulation above joists ( $\lambda = 0.044 \text{ W/mK}$ )

Assumptions: Timber joist fraction 9% (joist at 600 ctrs).  
Air gap correction = 0  
Loft hatch insulation 50mm ( $\lambda 0.044$ )

U-value	Insulation thickness	
	Between joists	Above joists
0.14 W/m <sup>2</sup> K	100 mm	200 mm
0.12 W/m <sup>2</sup> K	100 mm	250 mm (100+150)
0.11 W/m <sup>2</sup> K	100 mm	300 mm (100+200)
0.09 W/m <sup>2</sup> K	100 mm	400 mm (200+200)

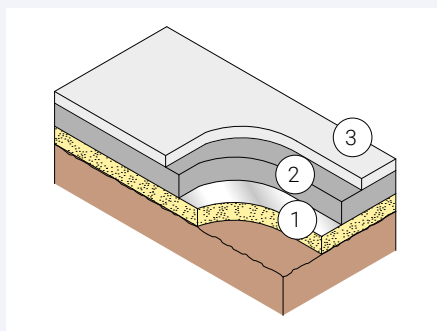

### Ground floor type 1: ground bearing slab

1. Rigid PIR insulation ( $\lambda = 0.022 \text{ W/mK}$ )
2. Reinforced concrete slab
3. 75 mm screed topping

Assumptions: The floor U-values have been calculated based on perimeter: area ratio of 0.56, as calculated for the detached house.  
Ground type: Clay/Silt

U-value	Insulation thickness
	Below slab
0.15 W/m <sup>2</sup> K	110 mm
0.13 W/m <sup>2</sup> K	130 mm
0.11 W/m <sup>2</sup> K	165 mm

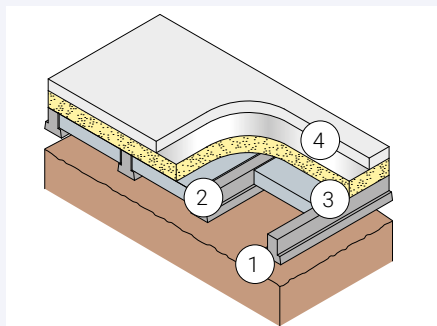

### Ground floor type 2: suspended beam and block floor

1. Ventilated void
2. Concrete beam and block
3. Rigid PIR insulation ( $\lambda = 0.022 \text{ W/mK}$ )
4. 75 mm screed topping

Assumptions: The floor U-values have been calculated based on perimeter: area ratio of 0.56, as calculated for the detached house.  
Ground type: Clay/Silt

U-value	Insulation thickness
	Below slab
0.15 W/m <sup>2</sup> K	120 mm
0.13 W/m <sup>2</sup> K	140 mm
0.11 W/m <sup>2</sup> K	165 mm



# U-values for construction elements

## U-values: external walls

U-value	Aircrete blockwork ( $\lambda = 0.15$ W/mK)		Lightweight blockwork ( $\lambda = 0.28$ W/mK)		Dense blockwork ( $\lambda = 1.33$ W/mK)	
	Insulation thickness	Wall thickness	Insulation thickness	Wall thickness	Insulation thickness	Wall thickness
0.25 W/m <sup>2</sup> K	100 mm	330 mm	100 mm	330 mm		
0.19 W/m <sup>2</sup> K			140 mm	370 mm	150 mm	380 mm
0.18 W/m <sup>2</sup> K	150 mm	380 mm	150 mm	380 mm	175 mm <sup>1</sup> (100+75)	405 mm <sup>1</sup>
0.15 W/m <sup>2</sup> K	185 mm <sup>1</sup> (100+85)	415 mm <sup>1</sup>	200 mm <sup>1</sup> (100+100)	430 mm <sup>1</sup>		

Where there is a blank cell, this means there isn't a practical combination of thicknesses for this U-value.

U-value	Aircrete blockwork ( $\lambda = 0.15$ W/mK)		Lightweight blockwork ( $\lambda = 0.28$ W/mK)		Dense blockwork ( $\lambda = 1.33$ W/mK)	
	Insulation thickness	Wall thickness	Insulation thickness	Wall thickness	Insulation thickness	Wall thickness
0.25 W/m <sup>2</sup> K	50 mm	330 mm	60 mm	340 mm	60 mm	340 mm
0.19 W/m <sup>2</sup> K	75 mm	355 mm	85 mm	365 mm	90 mm	370 mm
0.18 W/m <sup>2</sup> K	85 mm	365 mm	90 mm	370 mm	95 mm	375 mm
0.15 W/m <sup>2</sup> K	85 mm <sup>2</sup> (85+35 int)	390 mm <sup>2</sup>	85 mm <sup>2</sup> (85+35 int)	390 mm <sup>2</sup>	100 mm <sup>2</sup> (100+50 int)	415 mm <sup>2</sup>

- Two layers of insulation within the cavity.
- Two layers of insulation, one in the cavity plus additional internal insulated plasterboard (int) required to achieve U-value 0.15W/m<sup>2</sup>K.

Notes: Based on 0.032  $\lambda$  glass mineral wool and 0.022  $\lambda$  PIR Insulation.  
Lower U-values may be achievable using higher performing products and materials.

- As the cavity width increases the number of wall ties increase, which impact the U-value.
- Wall tie correction: stainless steel, 2.5m<sup>2</sup>, 0-100mm insulation thickness, 12.5mm<sup>2</sup> cross sectional area.
  - Wall tie correction: stainless steel, 2.5m<sup>2</sup>, 101-150mm insulation thickness, 24mm<sup>2</sup> cross sectional area.
  - Wall tie correction: stainless steel, 2.5m<sup>2</sup>, >150mm insulation thickness, 60mm<sup>2</sup> cross sectional area.

### Wall type 1: fully filled external wall

- Plasterboard on dabs
- 100 mm blockwork
- Mineral wool insulation ( $\lambda = 0.032$  W/mK)
- Wall ties: Stainless steel
- 100 mm brickwork

Assumptions:

Mortar bridge: 0.15 and 0.28 block ( $\lambda=0.88$  W/mK)/6.7% as per BR443.

Air gap correction = 0

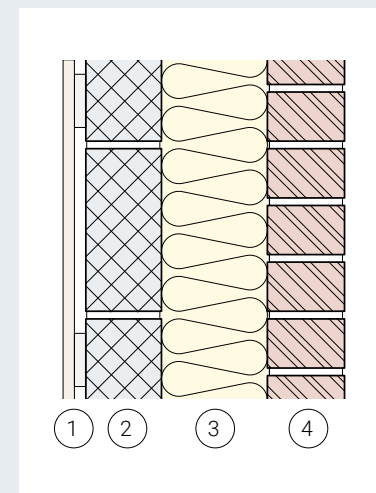

### Wall type 2: partially filled external wall

- Plasterboard on dabs
- 100 mm blockwork
- Rigid PIR insulation ( $\lambda = 0.022$  W/mK)
- Minimum 50 mm clear cavity
- Wall ties: Stainless steel
- 100 mm brickwork

Assumptions:

Mortar bridge: 0.15 and 0.28 block ( $\lambda=0.88$  W/mK)/6.7% as per BR443.

Air gap correction = 1

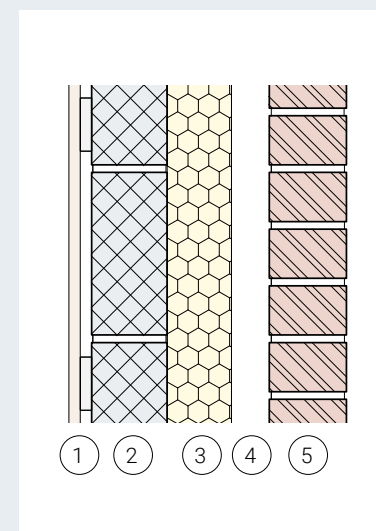

# House type and modelling assumptions

## END TERRACE



FRONT ELEVATION

REAR ELEVATION

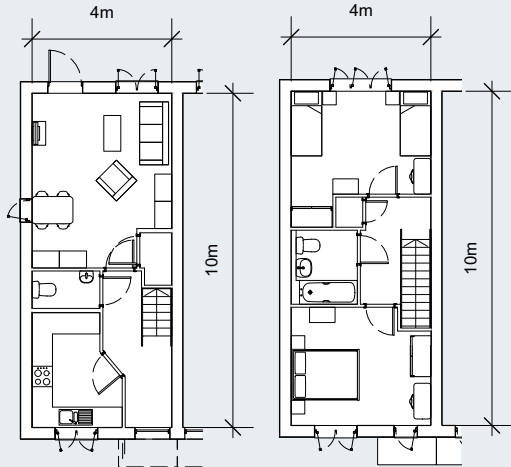

GROUND FLOOR

FIRST FLOOR

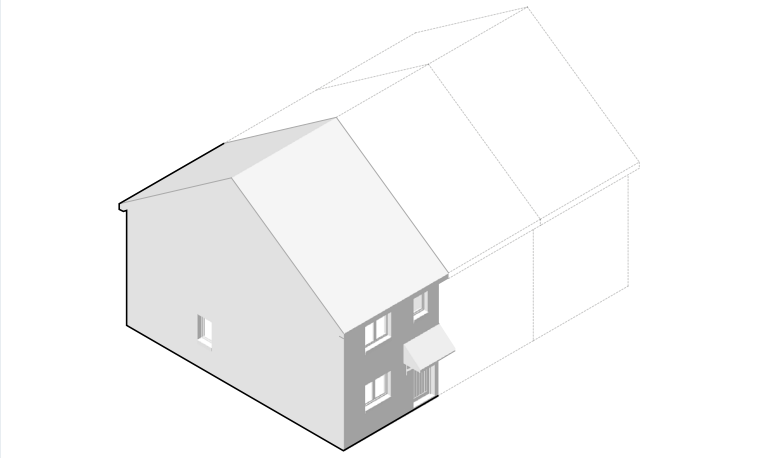

Gross internal area: 80.6 m<sup>2</sup>

## MID TERRACE



FRONT ELEVATION

REAR ELEVATION

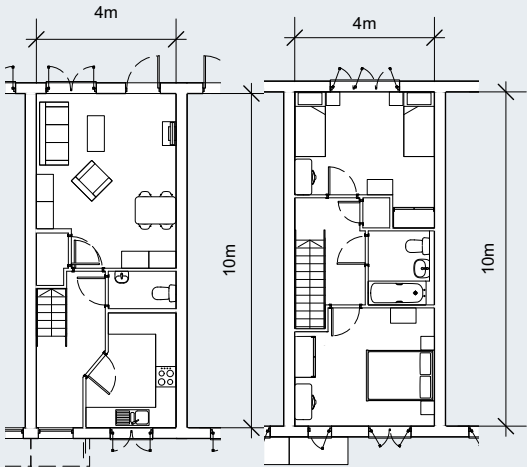

GROUND FLOOR

FIRST FLOOR

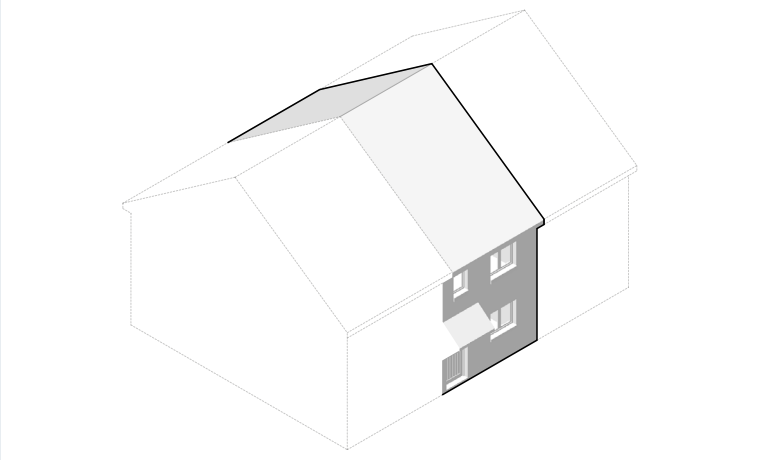

Gross internal area: 80.6 m<sup>2</sup>

# House type and modelling assumptions

## DETACHED



FRONT ELEVATION

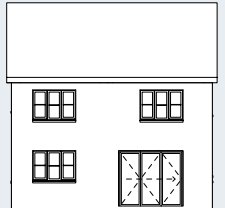

REAR ELEVATION

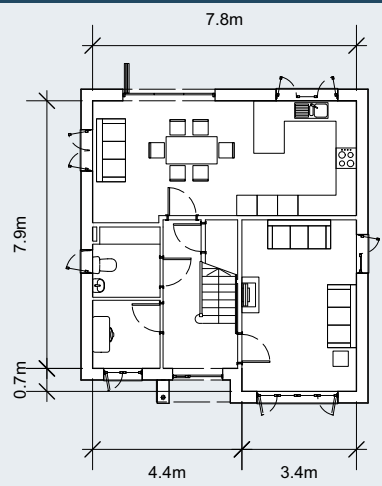

GROUND FLOOR

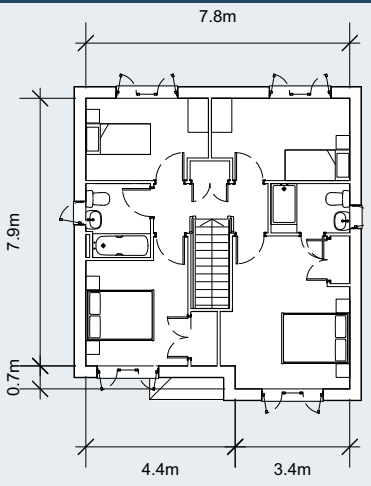

FIRST FLOOR

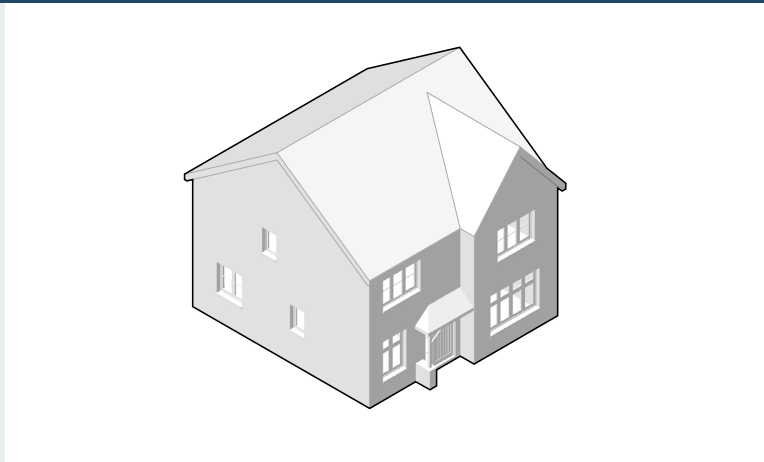

Gross internal area: 126.5 m<sup>2</sup>

## ROOM IN THE ROOF - SEMI DETACHED



FRONT ELEVATION

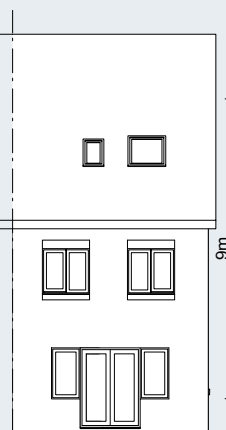

REAR ELEVATION

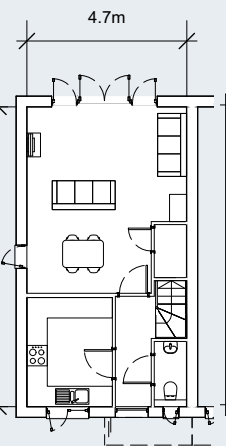

GROUND FLOOR

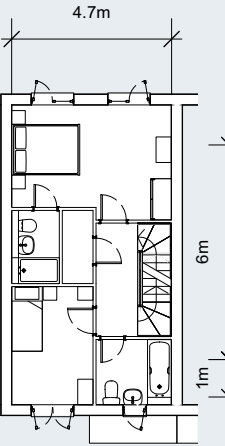

FIRST FLOOR

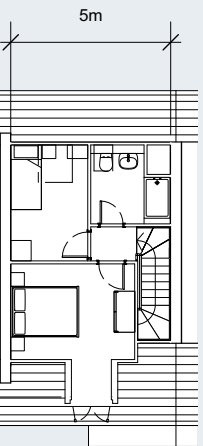

ROOM IN ROOF

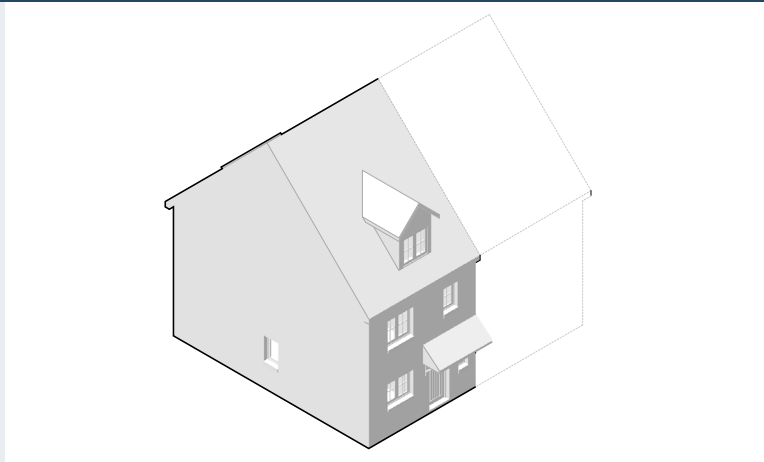

Gross internal area: 112.9 m<sup>2</sup>

## Thermal bridging assumptions

Summary of Thermal Bridging Psi-values used in modelling work - Full Fill Masonry						
	Junction detail	Ref	Default Psi <sup>1</sup>	Notional Psi <sup>2</sup>	Used in this Guide	
					Set A <sup>3</sup>	Set B <sup>4</sup>
Junctions with an external wall	Other lintels (Insulated)	E2	1.00	n/a	0.175	n/a
	Other lintels (Thermally broken)	E2	n/a	0.05	0.050	0.050
	Sill	E3	0.10	0.05	0.038	0.028
	Jamb	E4	0.10	0.05	0.041	0.024
	Ground floor (beam & block)	E5	0.32	0.16	0.060	0.047
	Intermediate floor within dwelling	E6	0.14	0.00	0.002	0.002
	Eaves (insulation at ceiling level)	E10	0.12	0.06	0.097	0.034
	Eaves (insulation at rafter level)	E11	0.15	0.04	0.041	0.024
	Gable (insulation at ceiling level)	E12	0.25	0.06	0.059	0.059
	Gable (insulation at rafter level)	E13	0.25	0.08	0.058	0.058
	Corner (normal)	E16	0.18	0.09	0.046	0.046
	Corner (inverted)	E17	0.00	-0.09	-0.082	-0.082
Party wall	E18	0.24	0.06	0.036	0.036	
Junctions with a party wall	Ground floor	P1	0.32	0.08	0.059	0.059
	Intermediate floor within dwelling	P2	0.00	0.00	0.000	0.000
	Roof (insulation at ceiling level)	P4	0.48	0.12	0.045	0.045
	Roof (insulation at rafter level)	P5	0.48	0.08	0.058	0.058
Junctions within a roof or with a room-in-roof	Head of roof window	R1	0.24	0.08	0.120	0.120
	Sill of roof window	R2	0.24	0.06	0.120	0.120
	Jamb of roof window	R3	0.24	0.08	0.120	0.120
	Ridge (vaulted ceiling)	R4	0.12	0.08	0.060	0.060
	Flat ceiling (inverted)	R7	0.12	0.04	0.060	0.060
	Roof to wall (flat ceiling)	R9	0.32	0.04	0.160	0.160

The thermal bridging Psi values used in the modelling work have been obtained from published sources with drawn junction details that could be built from. The exception is the room-in-roof junctions where half the SAP table K1 default value has been taken. We have had to make this assumption because there are currently no published details for these junctions that a small builder can readily access. This assumption has been checked against calculated values for proprietary systems and been found to be conservative. Overall we have tried to strike a balance between buildable details and good Psi values. We have also taken the simplified assumption to use the same Psi values (Set A) for the 100mm cavity example and the 2021 notional dwelling (apart from upgrading insulated lintels to thermally broken or split lintels where required for TFEE). The FHS fabric example uses a different set of Psi-values (Set B) appropriate to a wall U-value of 0.15 W/m<sup>2</sup>.K.

Junction details and associated Psi values used in actual dwelling modelling must match the construction type and materials used. Over time, a greater number of published details will become available. As noted on page 17, the Building Alliance will shortly be publishing a full set of Psi values and construction details, and manufacturers will increasingly provide calculated Psi values for standard construction details using their products.

<sup>1</sup> From SAP10.2 Table K1. To be used where specific Psi-values are not available for a particular junction. Refer to SAP Appendix K for details.

<sup>2</sup> From SAP10.2 Table R2. These values are used in the Notional building (to calculate the TFEE, TER & TPER) and cannot be used in your actual dwelling.

<sup>3</sup> This set used for the example dwellings modelled in this guide with wall U-value of 0.19 or above. Most values taken from *H+H Calculated Ψ-values*, dated 8<sup>th</sup> July 2021.

<sup>4</sup> This set used for the example dwellings modelled in this guide with wall U-value of 0.15. Most values taken from *H+H Calculated Ψ-values*, dated 8<sup>th</sup> July 2021. Supplementary values from *Designed to Perform: An Illustrated Guide to Delivering Energy Efficient Homes* by Tom Dollard, RIBA 2022.

**Table 1.1 Summary of notional dwelling specification for new dwelling<sup>(1)</sup>**

Element or system	Reference value for target setting
Opening areas (windows, roof windows, rooflights and doors)	Same as for actual dwelling not exceeding a total area of openings of 25% of total floor area <sup>(2)</sup>
External walls including semi-exposed walls	U = 0.18 W/(m <sup>2</sup> .K)
Party walls	U = 0
Floors	U = 0.13 W/(m <sup>2</sup> .K)
Roofs	U = 0.11 W/(m <sup>2</sup> .K)
Opaque door (less than 30% glazed area)	U = 1.0 W/(m <sup>2</sup> .K)
Semi-glazed door (30–60% glazed area)	U = 1.0 W/(m <sup>2</sup> .K)
Windows and glazed doors with greater than 60% glazed area	U = 1.2 W/(m <sup>2</sup> .K) Frame factor = 0.7
Roof windows	U = 1.2 W/(m <sup>2</sup> .K), when in vertical position (for correction due to angle, see specification in SAP 10 Appendix R)
Rooflights	U = 1.7 W/(m <sup>2</sup> .K), when in horizontal position (for correction due to angle, see specification in SAP 10 Appendix R)
Ventilation system	Natural ventilation with intermittent extract fans
Air permeability	5 m <sup>3</sup> /(h.m <sup>2</sup> ) at 50 Pa
Main heating fuel (space and water)	Mains gas
Heating system	Boiler and radiators Central heating pump 2013 or later, in heated space Design flow temperature = 55 °C
Boiler	Efficiency, SEDBUK 2009 = 89.5%
Heating system controls	Boiler interlock, ErP Class V Either: – single storey dwelling in which the living area is greater than 70% of the total floor area: programmer and room thermostat – any other dwelling: time and temperature zone control, thermostatic radiator valves
Hot water system	Heated by boiler (regular or combi as above) Separate time control for space and water heating
Wastewater heat recovery (WWHR)	All showers connected to WWHR, including showers over baths Instantaneous WWHR with 36% recovery efficiency utilisation of 0.98
Hot water cylinder	If cylinder, declared loss factor = 0.85 × (0.2 + 0.051 V <sup>2/3</sup> ) kWh/day where V is the volume of the cylinder in litres
Lighting	Fixed lighting capacity (lm) = 185 × total floor area Efficacy of all fixed lighting = 80 lm/W
Air conditioning	None
Photovoltaic (PV) system	For houses: kWp = 40% of ground floor area, including unheated spaces / 6.5 For flats: kWp = 40% of dwelling floor area / (6.5 × number of storeys in block) System facing south-east or south-west

**NOTE:**  
1. For a dwelling connected to an existing district heat network, an alternative notional building is used. See paragraph 1.8 and SAP 10.  
2. See SAP 10 for details.

Extract from: Future Homes Consultation 2019 summary of responses and government response document p. 106/7.

## Annex A - Draft notional building specification for the Future Homes Standard

- A.1 The introduction of the Future Homes Standard will ensure that from 2025, an average home will produce at least 75% lower CO<sub>2</sub> emissions than one built to current energy efficiency requirements. In the short term this represents a considerable improvement in energy efficiency standards for new homes. Homes built under the Future Homes Standard will be 'zero carbon ready', which means that in the longer term, these homes will be future-proofed with low carbon heating and world-leading levels of energy efficiency. No further retrofit work will be necessary to enable them to become zero carbon homes as the electricity grid continues to decarbonise.
- A.2 By delivering carbon reductions through the fabric and building services in a home rather than relying on wider carbon offsetting, the Future Homes Standard will ensure new homes have a smaller carbon footprint than any previous Government policy. In addition, this footprint will continue to reduce over time as the electricity grid decarbonises.
- A.3 To illustrate the type of homes we expect to be built under the Future Homes Standard, the October 2019 consultation proposed a draft specification that included the minimum fabric standards we expect these homes might incorporate. Under the Future Homes Standard, we will be pushing building fabric standards further than ever before while ensuring that low carbon heating is integral to the design of all new homes.
- A.4 The table below sets out a draft notional building specification that will form the basis of the Future Homes Standard. While the draft specification for the Future Homes Standard is not final and will be subject to further technical work and full consultation in due course, we are sharing this now so that we can begin to engage with all parts of industry on the indicative technical detail of the Future Homes Standard.

**Table A - Draft Future Homes Standard specification**

	Indicative FHS specification <sup>2</sup>
Floor U-value (W/m <sup>2</sup> .K)	0.11
External wall U-value (W/m <sup>2</sup> .K)	0.15
Roof U-value (W/m <sup>2</sup> .K)	0.11
Window U-value (W/m <sup>2</sup> .K)	0.8
Door U-value (W/m <sup>2</sup> .K)	1.0
Air permeability (m <sup>3</sup> /(h.m <sup>2</sup> ))	5.0
Heating appliance	Low-carbon heating (e.g. Heat pump)
Heat Emitter type	Low temperature heating
Ventilation System type	Natural (with extract fans)
PV	None
Wastewater heat recovery	No
γ value (W/m <sup>2</sup> .K)	0.05

## Glossary

**Accredited Construction Details (ACDs):** Typical construction details which were published in 2007 by the Department for Communities and Local Government to address issues with continuity of thermal and airtightness layers in construction. While ACDs are largely out of date, they have not been withdrawn and are still available for use.

**Air permeability:** The measure of airtightness of the building fabric. It is defined as the air leakage rate per hour per m<sup>2</sup> of envelope area at the test reference pressure differential of 50Pa or 4Pa.

**Appendix R:** Included in SAP 10.2.2021, this appendix contains the reference values for the parameters of the SAP calculation which are used to establish the Target Fabric Energy Efficiency (TFEE), Target CO<sub>2</sub> emission rates (TER), and Target Primary Energy Rate (TPER) for demonstrating compliance in new homes.

**Carbon dioxide (CO<sub>2</sub>) emissions:** The release of carbon dioxide into the atmosphere, largely as a result of burning fossil fuels such as coal, gas and oil to produce heat and electricity.

**Cold roof:** A form of roof construction where the insulation is placed between the ceiling joists and outside air is allowed to ventilate through the loft space.

**Design air permeability:** The target value set at design stage and evaluated through a mandatory testing regime outlined in ADLv1 2021.

**Dwelling Emission Rate (DER):** A measure of carbon dioxide emissions arising from use of regulated energy in homes as calculated by the approved National Calculation Methodology, SAP. It is expressed as kgCO<sub>2</sub>/(m<sup>2</sup>.yr) and takes into account energy used for space heating, hot water, fixed internal lighting, fans and pumps. To demonstrate compliance with ADLv1 2021, the DER of a dwelling must be no greater than its corresponding Target Emission Rate (TER).

**Dwelling Fabric Energy Efficiency (DFEE):** A measure of the space heating and cooling demand of a home, expressed in terms of kWh/(m<sup>2</sup>.yr), and considers U-values, thermal bridging, air permeability, thermal mass and any features that affect solar gains. To demonstrate compliance with ADLv1 2021, the DFEE of a dwelling must be no greater than its corresponding Target Fabric Energy Efficiency (TFEE).

**Dwelling Primary Energy Rate (DPER):** Expressed as kWh<sub>PE</sub>/(m<sup>2</sup>.year) and determined using the Standard Assessment Procedure.

**Frame Factor:** Ratio of glazing area of the window to the whole window.

**g-value:** Total solar heat gain / incident solar radiation.

**MVHR:** Mechanical ventilation with heat recovery - a system of fans and ducts that recovers waste heat from outgoing air and pre-heats incoming air.

**Natural ventilation:** The supply of adequate fresh air to the home through windows, trickle ventilators, etc. Removal of air may take place by natural or mechanical means (via intermittent extracts).

**Notional dwelling:** In SAP, this is a notional home of the same size and shape as the new home, which is created based on the reference values in Appendix R. This notional home is used to calculate the TER and TFEE values against which the new home is assessed.

**Psi-value:** Psi-value or linear thermal transmittance is the measure of heat loss along a non-repeating thermal bridge calculated as per guidance in BR 497 (2nd edition 2016) and IP 1/06 (2006); expressed in terms of W/mK.

**Renewable energy:** Energy produced without using finite fossil fuels (such as coal, oil and gas) and with minimal emissions of greenhouse gases. The main renewable energy sources are wind power, solar power, hydro-power and geothermal energy.

**SAP:** Standard Assessment Procedure; the Government's approved method for calculating energy efficiency and carbon emissions primary energy, energy cost and SAP rating from homes to demonstrate compliance with Building Regulations.

**Target Emission Rate (TER):** The target emission rate as calculated by SAP for a particular home expressed as annual kg of CO<sub>2</sub> per square metre of floor area. The calculation is based on a notional dwelling of the same size and shape as the proposed dwelling using the reference values in SAP Appendix R.

**Target Fabric Energy Efficiency (TFEE) rate:** The target fabric energy efficiency rate as calculated by SAP for a particular home and is expressed as kWh/(m<sup>2</sup>.yr). The calculation is based on a concurrent notional dwelling of the same size and shape as the proposed dwelling, using the reference values in SAP Appendix R.

**Target Primary Energy Rate (TPER):** Additional compliance metric added for 2021, the target primary energy rate as calculated by SAP for a particular home and is expressed as kWhPE/(m<sup>2</sup>.yr). The calculation is based on a notional dwelling of the same size and shape as the proposed dwelling using the reference values in SAP Appendix R.

**Thermal conductivity:** The theoretical rate at which a material conducts heat across a unit thickness; expressed in terms of W/mK.

**U-value:** The calculated rate at which heat is lost per unit area of a building element; expressed in terms of W/m<sup>2</sup>K.

**Y-value:** Overall heat loss from linear thermal bridging, expressed in W/m<sup>2</sup>K.

## References

**Approved Document B, Fire Safety, Volume 1: Dwellings, The Building Regulations 2010**, (NBS, 2019 edition incorporating 2020 amendments - for use in England.)

**The Building Regulations 2010, Protection from falling, collision and impact, Approved Document K**, (NBS, 2013 edition - for use in England.)

**Approved Document L, Conservation of fuel and power, Volume: Dwellings, The Building Regulations 2010**, (NBS, 2021 edition - for use in England): paragraph 1.4, table 1.1, Appendix B: The Buildings Regulation England Part L (BREL) report.

**Approved Document O, Overheating, The Building Regulations 2010**, (NBS, 2021 edition - for use in England): tables 1.1, 1.3.

**Approved Document S, Infrastructure for the charging of electric vehicles, The Building Regulations 2010**, (NBS, 2021 edition - for use in England.)

**Assessing the effects of thermal bridging at junctions and around openings (IP 1/06)** (BRE Press, March 2006).

**Conventions for calculating linear thermal transmittance and temperature factors (BR 497)** (2nd edition 2016)

**ena Energy Network Association Databases**, available online: <https://www.energynetworks.org/industry-hub/databases>

**Energy Saving Trust**, available online: <https://energysavingtrust.org.uk>

**Future Homes Delivery Plan, Future Homes Task Force**, 27th July 2021, available online: <https://irp.cdn-website.com/bdbb2d99/files/uploaded/Press%20Release%20Future%20Homes%20Delivery%20Plan%2027%20July%202021%20Final.pdf>

**Guidance, How to register energy devices in homes or small businesses: guidance for device owners and installation contractors** (Published 31st March 2021), available online: <https://www.gov.uk/government/publications/register-energy-devices-in-homes-or-small-businesses-guidance-for-device-owners-and-installation-contractors/register-energy-devices-in-homes-or-small-businesses-guidance-for-device-owners-and-installation-contractors>

**H+H Partners in wall building, Calculated  $\Psi$  values**, (current version: first issue, July 2021), available online: <https://www.hhcelcon.co.uk/psi-values>

Future Homes Hub | Part L 2021 Where to start : Masonry Construction

**Independent Networks Association**, available online: <https://ina.org.uk>

**Innovate UK, Building Performance Evaluation Programme: Findings from domestic projects, making reality match design**, (January 2016), available online: <https://www.ukri.org/wp-content/uploads/2021/12/IUK-071221-DomesticBuildingPerformanceReport2016.pdf>

**Ministry of Housing, Communities & Local Government, The Future Homes Standard: 2019 Consultation on changes to Part L (conservation of fuel and power) and Part L (ventilation) of the Building Regulations for new dwellings, Summary of responses received and Government response**. (January 2021) Annex A - P106-107, available online: [https://assets.publishing.service.gov.uk/government/uploads/system/uploads/attachment\\_data/file/956094/Government\\_response\\_to\\_Future\\_Homes\\_Standard\\_consultation.pdf](https://assets.publishing.service.gov.uk/government/uploads/system/uploads/attachment_data/file/956094/Government_response_to_Future_Homes_Standard_consultation.pdf)

**MCS MIS3005-D Heat Pump Design**, available online: <https://mcscertified.com/wp-content/uploads/2021/12/MIS-3005-D-Heat-Pump-Design-Issue-1.0.pdf>

**MCS MIS3005-I Heat Pump Installation**, available online: <https://mcscertified.com/wp-content/uploads/2021/12/MIS-3005-I-Heat-Pump-Installation-Issue-1.0.pdf>

**NHBC Foundation, Part L 2013 - where to start: an introduction for house builders and designers - masonry construction (for England) (NF58)**, (Published 06.11.2014).

**The Government's Standard Assessment Procedure for Energy Rating of Dwellings, SAP 10.2**, (version 10.2 (17-12-2021): Appendix R.

**The Zero Carbon Hub, Thermal Bridging Guide**, available online: <https://www.zerocarbonhub.org/resources/reports/thermal-bridging-guide>

**Vaillant, Air-to-water domestic hot water heat pump**, available online: <https://www.vaillant.co.uk/for-installers/products/arosstor-domestic-hot-water-heat-pump-58880.html>

For the full schedule of publications by the Future Homes Hub, visit <https://www.futurehomes.org.uk/library>